



710 Orange St., Ashland, Ohio 44805
(419) 289-1500 (800) 462-3790

INSTALLATION INSTRUCTIONS

Provectr *Plus*

(with ISOBAR® Control Valve)

For Models:

AF9PAC

AF10PAC

AF12PAC

AF13PAC

How The PROVECTR *Plus* Works

The Provectr *Plus* requires no chemicals for its operation. It consists of two components: (1) AP tank with air compressor and (2) Filter tank. The first item serves to oxidize and precipitate Iron and Sulfur so that the filter can later remove them. The water flows down through the mineral bed of the filter and out the service lines. The collected precipitates must be regularly removed from the filter by reversing the flow of water through the filter running to drain. Called "Backwashing" and lasting 10 minutes, the process expands the mineral freeing the iron, sulfur, MN and turbidity, which are washed out of the filter to the drain. It is important that the correct amount of water is available for the Backwash Cycle. Check pumping capacity to be certain water is available in sufficient volume to adequately backwash the equipment at the specified rate. (See Specifications)

General Specifications	AF9PAC	AF10PAC	AF12PAC	AF13PAC
Filter Media Type	Multi-Blend	Multi-Blend	Multi-Blend	Multi-Blend
Filter Media Capacity Cu. Ft.	1	1.5	2	2.5
D-Gravel	Not Required	Not Required	Not Required	Not Required
AP Tank	10 x 54	10 x 54	10 x 54	10 x 54
Mineral Tank (Vortech)	9 x 48	10 x 54	13 x 48	13 x 54
Air Compressor	1	1	1	1
Relay Box	1	1	1	1
Service Flow Rate Continuous	4gpm	5gpm	6gpm	7gpm
Service Flow Rate Intermittent	5gpm	6gpm	7gpm	8gpm
Backwash Flow Rate	5gpm	5gpm	7gpm	7gpm
Gallons Used Per Backwash	130	130	156	182
Space Required (DxWxH)	10x19x68	10x20x68	13x23x68	13x23x68
Approximate Shipping Weight	143#	175#	220#	280#

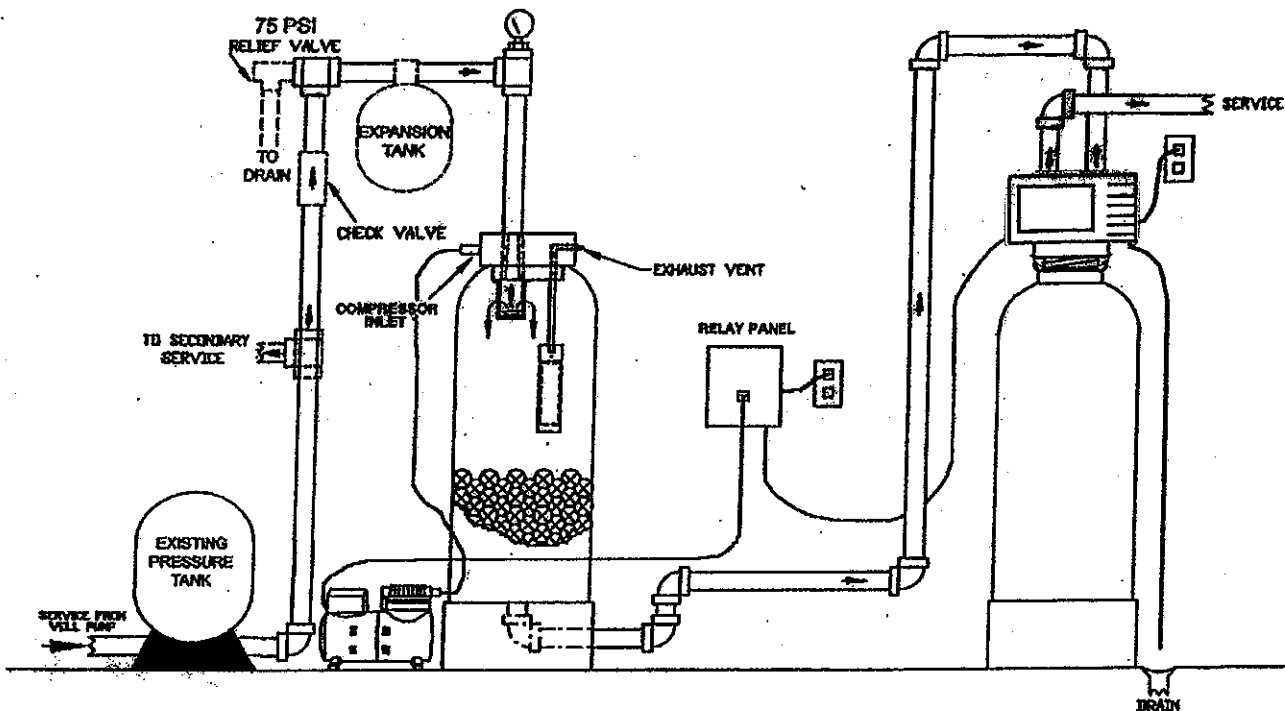

Note – Items shown in dashed lines are required for unfiltered secondary service only. Relief valve and / or expansion tank must be installed between check valve and AP tank assembly.

Installation Requirements

AP Tank

- A level floor position after the pressure tank. (See diagram on pg. 2)
- DO NOT install in an area of direct sunlight or where freezing temperatures may occur

Filter Tank

- A level floor position ahead of piping into water heater
- Unit must be installed at least 10 ft. ahead of the inlet to a water heater to prevent damage due to back up of hot water

Relay Box

- Locate relay box near the filter tank and an unswitched 120v / 60 Hz grounded outlet.
- You will notice an 8ft. meter cord and plug attached.

Note:

If household plumbing is galvanized and you intend to make an installation with copper or vice versa, obtain dielectric unions to prevent dissimilar metal corrosion.

- Where the drain line is elevated above the control valve or exceeds 20ft. in length to reach the drain, use 3/4in. I.D. drain line tubing instead of 1/2in.
- When sweat soldering copper pipe, remember to always use lead free solder and flux. Cover yoke and bypass valve with wet rags to prevent heat damage to connections and control valve. If using PVC or plastic pipe, primers and solvent cements specifically recommended for use with potable water are required.
- **ALWAYS FOLLOW LOCAL PLUMBING CODES**
- All plumbing lines not requiring treated water should be connected upstream of the Provectr *Plus* tank. (See diagram on pg. 2)



Installation Procedure

1. Position AP tank and Filter tank at the desired location. The AP tank must be installed between the pump/pressure tank and filter tank. If a water softener is to be installed, it should be positioned after the filter tank.
2. The filter media is shipped separately from the filter tank and should be loaded prior to installation.
 - a) Remove control valve by unscrewing it from the filter tank.
 - b) Plug distributor to prevent any media from entering the inside of the tube.
 - c) Place media funnel onto tank and fill tank 1/3 with water
 - d) Pour in media. Never fill tank more than 2/3 full to allow room for backwash. Since the Provectr comes with a Vortech tank, gravel is NOT needed.
 - e) Remove plug and replace control valve.
3. Turn off main water supply and open nearest faucet to relieve pressure.
4. Cut main line and install the AP tank and Filter tank.
5. Turn on main water supply and allow water to flow through new plumbing and keep the nearest faucet open to evacuate air.
6. Check for leaks.
7. If no leaks, proceed by slowly opening the bypass and allow water to fill the filter tank.
8. Allow water to run through the filter for a few minutes and then turn off the nearest faucet.

Drain Line

1. Remove drain line elbow and wrap threads with teflon tape, replace elbow and attach ½ in. I.D. tubing.
2. As an option you may also use 1/2in PVC piping instead of the tubing.
3. Run tubing or PVC to a suitable drain. Allow a 4in air gap between the drain line and drain to prevent siphoning.
4. On the AP tank manifold, there is a 1/4in. hose barb. With the tubing provided, push tubing onto hose barb and run it to drain. This is a precaution in the case that the float should ever fail.
5. Never tee drain lines together.

Air Compressor / Relay Box

1. Locate the air compressor in close proximity to the AP tank assy.
2. Connect the supplied tubing to the compressor and the other end to the AP tank manifold insert.
3. Insert the compressor's electrical plug into the relay box.
4. Insert the electrical plug from the relay box to an unswitched 120v / 60 Hz grounded outlet.
5. Attached to the relay box is the meter cable. Insert the meter cable to the meter located in between the bypass valve and the Isobar control valve.

Note: As water flows through the filter, the meter will turn and send a signal to the relay box and the relay box will turn on the air compressor. Make sure air compressor switch is turned on.

Start up

- 1) Plug Isobar control valve into an unswitched 120v / 60 Hz grounded outlet.
- 2) Set time of day by pushing the black time set button in and rotating the 24hr gear until the current time of day appears in the time of day window.
- 3) Pull the proper pins out on skipper wheel according to the **Provectr Backwash Guidelines** located on page. 7
- 4) Turn manual regeneration knob clockwise until backwash appears in the window. Backwash the filter for several minutes to rinse all fines from the media.
- 5) Once backwash water is clear. Turn dial clockwise back to in the service position.
- 6) The Provectr *Plus* is now ready.

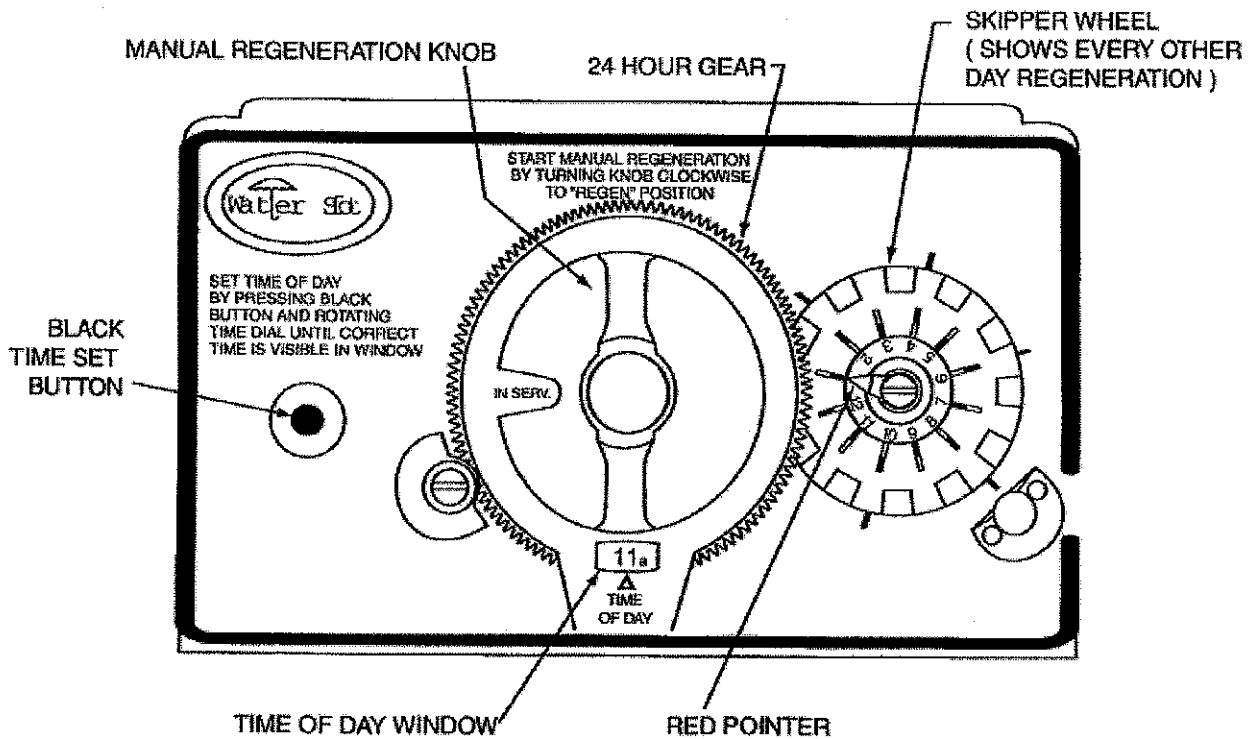

Water SoftTM inc.

Servicing Guide

This service guide does not cover every possible maintenance situation with your unit. If you need further assistance, please check with your dealer or installer or call the factory direct.

Cleaning the 2092 Control Valve of an Automatic Filter

Control valves sometimes have to be disassembled and cleaned. The most common reason is that they are plugged with iron or iron bacteria. Sediment or other debris in the raw water as well as mineral from the inside of the tank can sometimes escape and find their way inside the valve. Common symptoms of a control valve that needs cleaning are: excessive pressure drop, continually leaking to drain, and a bound up piston resulting in excessive pressure required to rotate the manual backwash dial on the valve to change cycles.

If you are having a problem with a control valve that needs cleaning too often, consider eliminating the cause of the problem. Iron bacteria buildup suggests chlorination is needed. Excessive sediment may indicate the need for a sediment filter.

1. If your system is equipped with a bypass valve, turn it to the "Bypass" position. Otherwise, turn the water supply off.
2. Index the manual backwash dial until "Backwash" appears in the window. This depressurizes the tank.
3. Unplug the control valve.
4. Disconnect the drain line.
5. For those units with bypass valves, locate the clips that hold the control valve to the bypass valve. Loosen the screws that hold clips, and loosen the clips. "Walk" the

tank/valve assembly away from the bypass valve. For those units without a bypass valve, walk the tank/valve assembly away from the yoke.

6. The control valve screws into the top of the media tank. Loosen but do not remove the valve from the top of the tank.
7. Open the control valve front cover. Remove the front cover by gently pulling the hinge pins from the pivot holes. Do the left side first, then the right.
8. Loosen the screws that hold the control valve back cover and remove the back cover.
9. Looking at the back of the control valve, locate the screw and washer that hold the drive yoke at the top of the piston to the drive gear in the powerhead. Remove this screw and washer.
10. Remove the two powerhead mounting screws and detach the powerhead by sliding it slightly forward and lifting up.
11. Carefully unscrew the control valve and remove it from the media tank. Try not to lift the distributor tube up from the tank. If the tube does lift up, you will have to "float" it back down by holding a garden hose on at the top and allowing the water pressure to "push" the media/gravel away from the bottom and allowing it to again rest on the tank bottom. Do Not Force The Tube Back Down.
12. Set the removed valve on a sturdy surface. Remove the three screws that hold the end plug retainer (the flat stainless steel plate). Lift off the end plug retainer.
13. Grasp the drive yoke on the top of the piston. Pull up to remove the piston from the valve body.
14. As you can now see, the piston moves inside a stack of

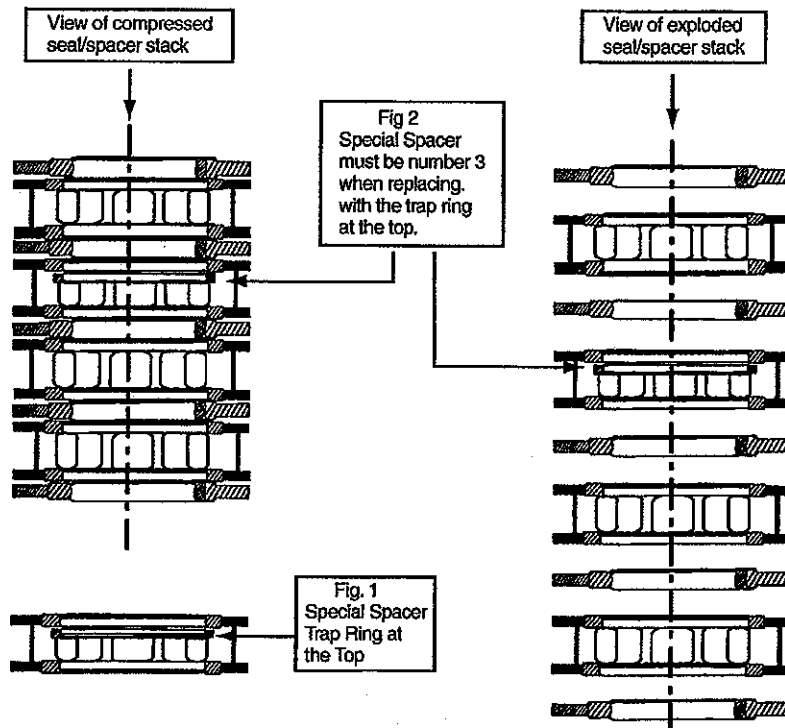

Servicing Guide

rubber seals and plastic spacer. Remove them. You should have five seals and four spacers. You now have the control valve disassembled.

15. Clean the control valve body completely. You may want to use a resin cleaner solution like Res Up to help you remove the deposits. Be sure to clean all the ports and passageways completely.
16. Inspect the piston for any signs of scoring or scratches. If you see that the piston is damaged, replace it. (P/N 20922C203)
17. Inspect the seals and spacers for damage. Particularly look at the inside edges of the rubber seals. If there is any damage, replace them. (P/N 20922C204)
18. To replace the seals and spacers in the control valve body, use the diagram following for the proper location of the "trap ring" spacer.
19. The seals and spacers need to be reinserted in the manner shown in the preceding diagram. Make sure the sequence is correct.
20. Lubricate the piston lightly with a food grade silicone grease (P/N 20561C550). Slide the piston down into the center of the seal and spacer stack.
21. As you reassemble the control valve and reattach it to the incoming plumbing, you should grease all O-rings with the same lubricant.
22. Put the end lug retainer in place on the top of the control valve. Fasten it with the three short screws. As you screw down the end plug retainer, you are compressing the stack of seals and spacers. It takes some force to do this. However if you find yourself deforming the end plug retainer, you are using too much force. This is telling you that the seals and spacers are not all seated properly. Remove the end plug retainer, the piston, and the seal/spacer stack. It is likely that the lower spacer is the one that is not seated properly. Carefully replace the seals and spacers and the piston. Replace the end plug retainer and screw it down.
23. Replace the powerhead (clock assembly) and fasten it with the two medium length screws. Seat the drive yoke on the drive gear in the powerhead. Replace the screw and washer that hold the drive yoke in place.
24. Lubricate the large O-ring on the base of the valve (where it seals to the tank) and the distributor tube O-rings seal in the counterbore at the bottom of the valve. Reattach the control valve to the tank by first insuring that the distributor tube is started into the counterbore and then screwing the valve hand tight into the tank. Do not use a wrench.
25. Install the power head cover and lid.
26. "Walk" the valve/tank assembly back into place to the bypass or yoke. Make sure to lubricate the O-ring seals. Reattach the valve to the plumbing.
27. Resupply water pressure to the filter; check for leaks.
28. Plug in the control valve and set the time of the day.
29. Perform a manual backwash to make sure the valve is working properly.

Provectr Backwash Guideline

This is a guideline offered to help in establishing a start point for setting the "day" intervals between backwashes on Provectr installations.

To work the formula, you need to know three (3) variables:

1. The cubic foot capacity of the unit installed.
2. The number of people using water from the system. (This is used to set the liters per day usage.)
3. The **Total** combined contaminant's in mg/L. (Iron, Manganese, and / or Hydrogen Sulfide) Note that a mg/L is equal to a ppm. These numbers come from the water analysis.

The constant factor in the equation is going to be that Each cubic foot of MultiBlend media is capable of removing 15,000 mg/L (or ppm) of contaminant's from the water between backwashes. If your unit has more than one cubic foot of media, multiply 15,000 by the number of cubic feet in the unit to find the removal capability.

To work the formula:

- a. Multiply the number of people by 284 liters per day (equal to about 75 gallons per person) to find the daily use (DU) in liters.
- b. Multiply daily use (DU) by the combined contaminant level (CCL) to find the contaminant level to be removed per day (RPD).
- c. Divide the constant factor of unit size you are installing (15,000 x No. of cu. Ft. = CF) by the removal per day (RPD) to find the days between backwashing (DAYS)

Example: You are installing an AF10P unit – 1.5 cu. Ft. – water test indicates a total of 7 mg/L (ppm) of contaminant level and the family using this unit has 4 people in it.

- a. Four people times 284 liters = 1136 liters per day to be treated (DU)
- b. 1136 times 7 (CCL combined contaminant) = 7952 required removal per day (RPD)
- c. Our unit is 1.5 cu. Ft. so we have a (1.5 x 15,000=22,500) 22,500 capacity divided by 7952 (RPD) equals 2.8 days between backwashings.

You should always round the "day" number down to fit the days timer capacity of the unit you are installing. For example, if your calculation came up with 5 days and you have a 12 day timer, you would need to set it at 4 day regeneration since a 5 day interval is not applicable.

It is also important to keep in mind that it may be necessary to make adjustments over a period of time to arrive at the correct settings.

Parts Diagrams

"2092" Control Valves Filter Bodies

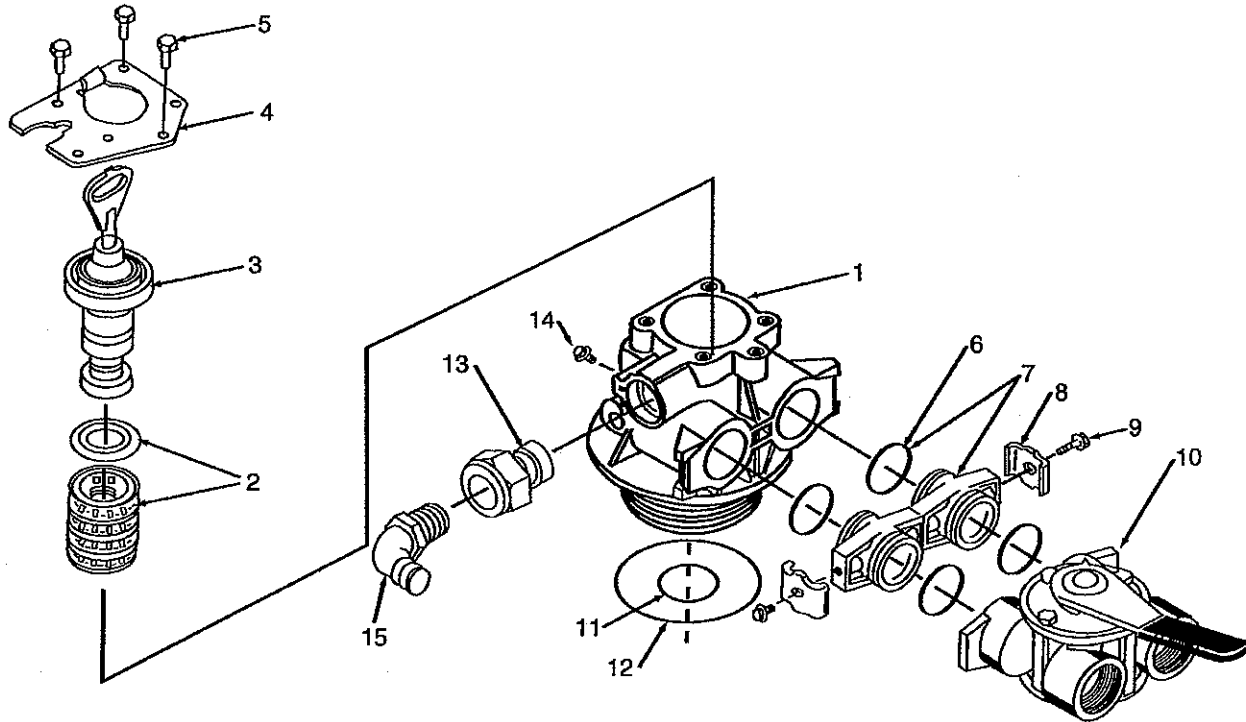

Ref. No.	Part No.	Description
1	20922C202	Body Filter
2	20922C204	Seal & Spacer Kit
3	20922C203	Piston & End Plug Ass'y
4	20561C249	Retainer End Plug
5	20561C250	Screw Hex HD 10-24 x 1/2" - 3 Req'd
6	20561C216	O Ring - 4 Req'd
7	20561C215	Adaptor - 2 Req'd
8	20561C201	Clip Adaptor - 2 Req'd
9	20561C217	Screw hex HD 8-18x5/8" - 2 Req'd
10	20561C270	Bypass 3/4" NPT
	20561C283	Bypass 1" NPT
11	90076C122	O Ring
12	20561C205	O Ring

Ref. No.	Part No.	Description
13	20251C258	Control Flow 5.0 GPM
13	20251C271	Control Flow 6.0 GPM
13	20251C259	Control Flow 7.0 GPM
		-Include Button & O Ring
	20251C261	Button 2.4 GPM
	20251C262	Button 5.0 GPM
	20251C265	Button 6.0 GPM
	20251C263	Button 7.0 GPM
	20251C254	O Ring
14	20251C229	Screw 6-32 x 1/2"
15	20251C255	Elbow 1/2" NPT x 1/2" Barb

Limited Warranty Water Treatment Equipment



This Warranty cannot be transferred – it is extended only to the original Purchaser or First User of the Product. By accepting and keeping this Product you agree to all of the warranty terms and limitations of liability described below.

[Mail Your Product Registration Card Within 30 Days of Purchase to Ensure Your Warranty Coverage or Proof of Purchase Will Be Required.]

IMPORTANT WARNING – READ CAREFULLY THE WATER SOFT™ WATER TREATMENT EQUIPMENT INSTALLATION, OPERATING AND MAINTENANCE INSTRUCTIONS MANUAL to avoid serious personal injury and property HAZARDS and to ensure safe use and proper care of this product.

MODEL NUMBERS COVERED

Water Softeners, Media Filters, UpFlow Filters, Provectrs, UV, RO, Filters, Chemical Feed

*FOR AS LONG AS YOU OWN AND LIVE IN YOUR SINGLE FAMILY HOME, this Warranty covers your water treatment equipment, if you are the first user of this Water Soft™ water treatment equipment and purchased it for single family home use – subject to all of the conditions, limitations and exclusions listed below. Purchasers who buy the Water Soft™ water treatment equipment for other purposes, and other component parts are subject to more limited warranties and you should read all of the terms included in this form to make sure you understand your Warranty.

WHAT IS COVERED BY THIS WARRANTY

Water Soft™ Inc. ("Water Soft") warrants that at the time of manufacture, the water treatment equipment shall be free from defects in material and workmanship as follows:

Thermoplastic Mineral Tanks.....	10 yrs.
Softener/Filter Control Valves.....	5 yrs.
Brine Tank Assemblies.....	3 yrs.
Chemical Feed Pumps.....	1 yr.
Reverse Osmosis System.....	1 yr.
Other Accessories & Parts.....	1 yr.

* This warranty does not include media and/or cartridge filter elements.

ADDITIONAL TERMS & CONDITIONS

What WATER SOFT Will Do If You Have a Covered Warranty Claim

WATER SOFT will at its option either make repairs to correct any defect in material or workmanship or supply and ship either new or used replacement parts or products. WATER SOFT will not accept any claims for labor or other costs.

ADDITIONAL EXCLUSIONS AND LIMITATIONS

This Warranty is non-transferable and does not cover any failure or problem unless it was caused solely by a defect in material or workmanship. In addition, this Warranty shall not apply:

- if the water treatment equipment is not correctly installed, operated, repaired and maintained as described in the INSTALLATION, OPERATING & MAINTENANCE INSTRUCTIONS Manual provided with the Product;
- if the tank is not the size indicated for the supply line size of the installation, as described in the Manual.
- if the unit has not always been operated within the factory calibrated temperature limits, and at a water pressure not exceeding 150 psi.
- to any failure or malfunction resulting from abuse (including freezing), improper or negligent handling, shipping (by anyone other than WATER SOFT), storage, use, operation, accident, or alteration, lightning, flooding or other environmental conditions;

• to any failure or malfunction resulting from failure to keep the unit full of potable water, free to circulate at all times; and with the tank free of damaging water sediment or scale deposits;

• this Warranty does not cover labor costs, shipping charges, service charges, delivery expenses, property damage, administrative fees or any costs incurred by the purchaser in removing or reinstalling the water treatment equipment.

• the Warranty does not cover any claims submitted to WATER SOFT more than 30 days after expiration of the applicable warranty time period described in this Warranty, and does not apply unless prompt notice of any claim is given to an authorized WATER SOFT distributor or to WATER SOFT and WATER SOFT or a designated contractor is provided access to the installation and to the water treatment equipment.

THESE WARRANTIES ARE GIVEN IN LIEU OF ALL OTHER EXPRESS WARRANTIES. NO WATER SOFT REPRESENTATIVE OR ANY OTHER PARTY IS AUTHORIZED TO MAKE ANY WARRANTY OTHER THAN THOSE EXPRESSLY CONTAINED IN THIS WARRANTY AGREEMENT.

ADDITIONAL WARRANTY LIMITATIONS

ANY IMPLIED WARRANTIES THE PURCHASER MAY HAVE, INCLUDING THE IMPLIED WARRANTIES OF MERCHANTABILITY AND FITNESS FOR A PARTICULAR PURPOSE, SHALL NOT EXTEND BEYOND THE APPLICABLE TIME PERIODS SPECIFIED ABOVE. Some states do not allow limitations on how long an implied Warranty lasts, so the above limitation may not apply to you.

LIMITATIONS OF REMEDIES

THE REMEDIES CONTAINED IN THIS WARRANTY ARE THE PURCHASER'S EXCLUSIVE REMEDIES. IN NO CIRCUMSTANCES WILL WATER SOFT OR THE SELLER OF THE PRODUCT BE LIABLE FOR MORE THAN, AND PURCHASER-USER'S REMEDIES SHALL NOT EXCEED, THE PRICE PAID FOR THE PRODUCT. IN NO CASE SHALL WATER SOFT OR SELLER BE LIABLE FOR ANY SPECIAL, INCIDENTAL, CONTINGENT OR CONSEQUENTIAL DAMAGES. Special, incidental, contingent and consequential damages for which WATER SOFT is not liable include, but are not limited to, inconvenience, loss or damage to property, consequential mold damage, loss of profits, loss of savings or revenue, loss of use of the products or any associated equipment, facilities, buildings or services, downtime, and the claims of third parties including customers. Some states do not allow the exclusion or the limitation of incidental or consequential damages, so the above limitation or exclusion may not apply to you.

WHAT TO DO IF YOU HAVE A PROBLEM COVERED BY THIS WARRANTY

Any Warranty coverage must be authorized by WATER SOFT. Contact the person from whom you purchased the Product, who must receive authorization from an WATER SOFT distributor or WATER SOFT. If you do not receive a prompt response, call WATER SOFT directly. Notice of a Warranty claim relating to replacement parts or products should be submitted by the authorized distributor to WATER SOFT at the following address:

If your Product is new and not used and you wish to return it, contact your WATER SOFT distributor.