



Installation / Operation Manual

PROVCTR Water Treatment System

Isobar Control Valve

For Model Numbers :

- AF9**
- AF10**
- AF12**
- AF13**

How The PROVECTR Works

The PROVECTR requires no chemicals for its operation. It consists of two components : (1) PROVECTR Tank and (2) Filter Tank. The first item serves to oxidize and precipitate iron and sulfur so that they can later be removed by the filter. The water flows down through the mineral bed of the filter and out to the service lines. The collected precipitates must be regularly removed from the filter by reversing the flow of water through the filter and running to drain. Called "Backwashing" and lasting 10 minutes, the process expands the mineral freeing the iron, sulfur and turbidity which is then washed out of the filter to the drain. It is important that the correct amount of water is available for the Backwash cycle. Check pumping capacity to be certain water is available in sufficient volume to adequately backwash the equipment at the specified rate.

The **Provectr™** uses the air we breath to naturally reduce the effects of Iron, Manganese and Sulfur Gas. By introducing oxygen to the water, contaminants chemically change to a physical particle that can be mechanically filtered out of this water. This natural process called *Oxidation*, is usually accomplished in other systems by using chemicals such as chlorine or potassium permanganate. Since the **Provectr™** does not use chemicals to treat the water, maintenance and chemical byproducts associated with these types of systems is eliminated. The energy required to operate this system is provided by using extra power that is available in your well pump to inject free air into the water. There are several normal side effects that may or may not occur when water is treated in this manner:

1. Cloudy or milky appearance to the treated water.

This side effect is usually more pronounced when the Iron, Manganese or Sulfur Gas levels are low. Since the **Provectr™** uses oxygen for the treatment of these contaminants, it can be expected to have some amount left over in the treated water. The higher contamination levels are, the less oxygen there will be. It is the oxygen that gives the cloudy or milky appearance. Once the faucet is opened and the water is drawn, pressure is released and allows the oxygen to escape. This usually will take from a few seconds to a minute depending on the amount of oxygen and the pressure. This noticeable side effect tells you the system is working properly and also will actually enhance the palatability of the water. It's oxygen that gives water it's fresh, crisp taste.

2. Sputtering or slight coughing from the hot water side faucets.

This is a normal phenomenon that usually occurs first thing in the morning. As the highly oxygenated **Provectr™** water is exposed to heat in the hot water tank a small amount of oxygen will separate. The longer the water is allowed to sit in the hot water tank, the more this will be noticed.

Usually, this will only occur if the hot water is allowed to sit idle for eight (8) hours or more. Consequently, when hot water is drawn after an extended period of no water use, a slight sputtering or coughing may be experienced for a few seconds. If this causes the hot water to splash out of the sink, the problem is reduced by simply turning on the cold water first and blending in the hot for several seconds. If there is a large amount of free air noticed on the *cold water side*, there is a possible malfunction of the system and your WaterSoft Dealer should be contacted to service the unit.

SYSTEM I TYPICAL INSTALLATION

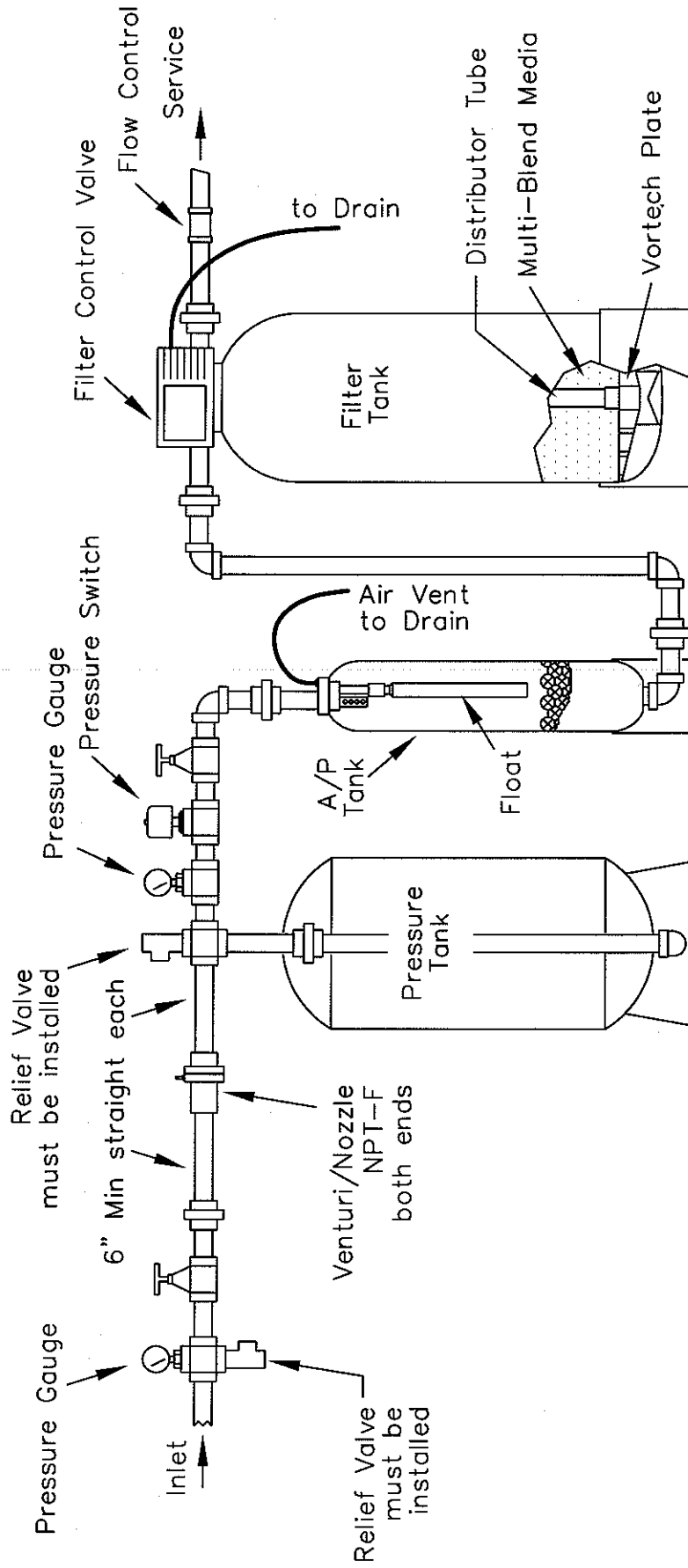

REV. 1/11/10

ARTWORK

A-PROVECTR SYSTEM I TYPICAL INSTALLATION

SYSTEM I "SUPERSIZE"

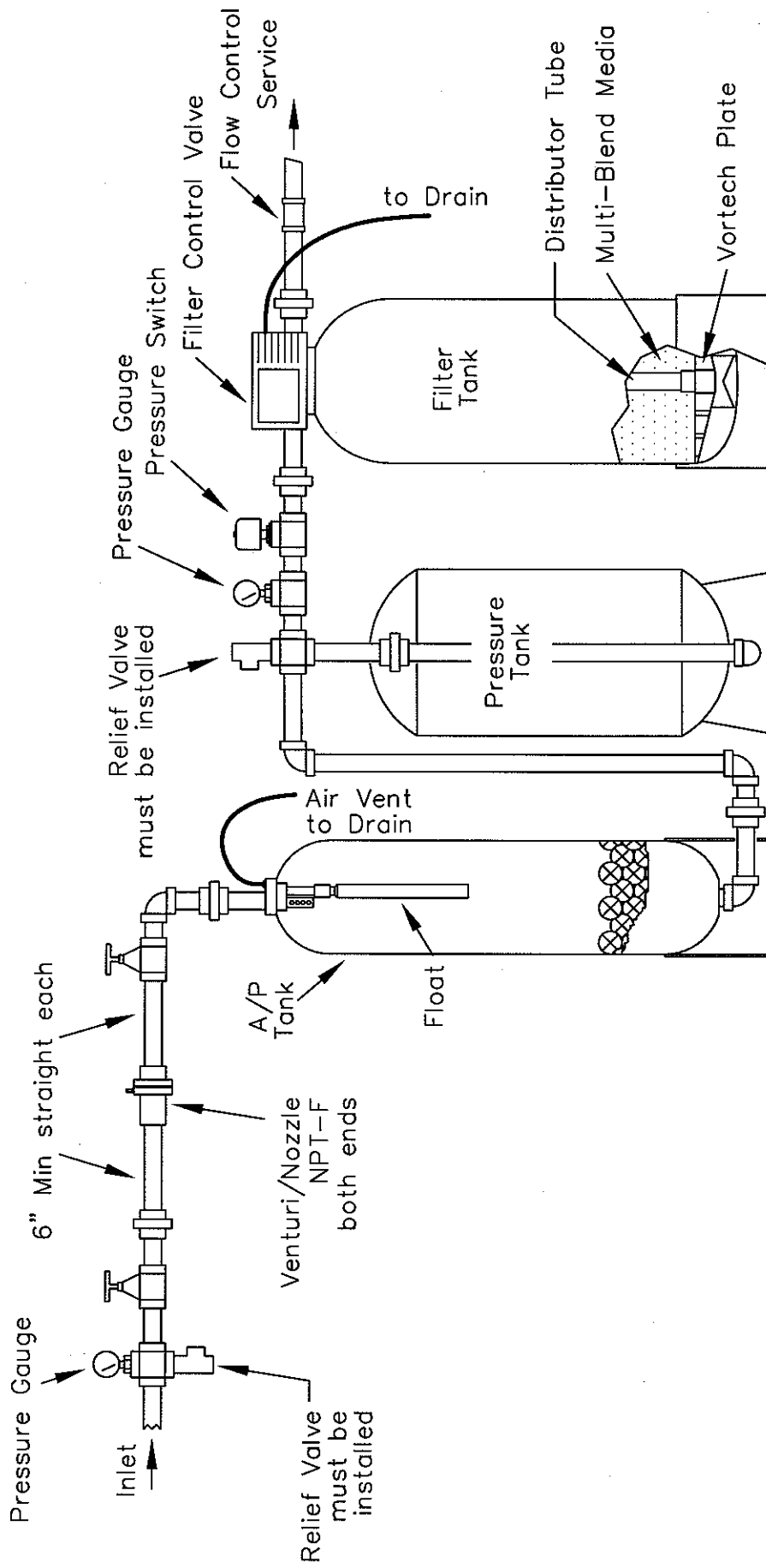

REV. 1/11/10

ARTWORK
A-PROVECTR SYSTEM I SUPERSIZE

Installation Requirements

A/P Tank

- A level floor position between the well pump and pressure tank. (See Typical Installation Diagram.)
- DO NOT install in an area of direct sunlight or where freezing temperatures may occur!

Filter Tank

- A level floor position ahead of piping into water heater.
- Unit must be installed at least 10' ahead of the inlet to a water heater to prevent damage due to back-up of hot water.
- DO NOT install the unit in an area of direct sunlight or where freezing temperatures may occur! (See Typical Installation Diagram.)

PROVECTR Location / Other Requirements

- Locate the filter near an unswitched, 120 volt / 60 Hz grounded electrical outlet.
- Check for distance and proper drain installation (e.g. floor drain, washing machine standpipe).
- Determine type and size of piping required for PROVECTR connection (e.g. galvanized, PVC plastic).

Note : If household plumbing is galvanized and you intend to make an installation with copper (or vice versa), obtain di-electric unions to prevent dissimilar metal corrosion.

Note : Where the drain line is elevated above the control valve or exceeds 20' in length to reach the drain, use 3/4" I.D. drain line tubing instead of 1/2" I.D. Drain line tubing is not included.

Caution : *When sweat soldering copper pipe (remember to always use lead free solder and flux), Cover yoke and bypass valve with wet rags to prevent heat damage to connections and control valve! If using PVC or plastic pipe, primers and solvent cements specifically recommended for use with potable water are required.*

Note : All plumbing lines not requiring "filtered" water should be connected "upstream" of the A/P Tank. (See Typical Installation Diagram.)

Installation Procedure

- Location of V/N -

The V/N will be installed in the water supply line between the water pump and in home pressure tank. The A/P tank and filter tank must be located after the pressure tank but before, for example, a water softener or water heater. Note : The exception to this A/P location is if you are installing a 10" x 54" "Supersize" A/P tank. In that case only will you place the A/P tank before the in home pressure tank. Because the system begins precipitating contaminant's at the V/N, the shorter and straighter the run from that location to the filter, the better the system will operate. Select a location near the pressure tank and a floor drain. All water in the home should be filtered with the possible exception of the outside faucets. Please remember that water taken before filtration will contain precipitated matter. Install in a reasonably dry area and protect from freezing. Handle all equipment with care when installing. An uninterrupted 115V circuit must be nearby.

- Water Supply Connection and Bypass Valve -

To allow for servicing, swimming pool filling or lawn sprinkling, a manual Bypass Valve has been installed at the factory. The Bypass allows raw water to be manually routed around the filter.

1. Position the A/P Tank and Filter Tank at desired location for installation. The A/P Tank & Venturi **must** be installed between the well pump and pressure tank. The filter tank must be installed after the pressure tank.(See Installation Diagram.) If a water softener is to be installed, it should be positioned after the filter tank.
2. The filter material is shipped separately from the Filter Tank. The Filter Tank must be loaded with material after tank has been placed at the desired location.
 - A. Remove the control valve by unscrewing from the tank.
 - B. Use a cork or tape to place over top of distributor tube to prevent media from entering tube while filling.
 - C. Place media funnel in hole on top of tank.
 - D. Pour several gallons of water in the tank. (Fill tank about 1/3 full.)
 - E. "D" gravel underbedding is not needed.
 - F. Pour in desired media to the correct level.

Note : 1/3 of the tank should be empty (Freeboard).

- G. After filling the tank with media, fill the tank completely with water.

Note : This will permit the filtering material to become soaked while preparing the installation and will prevent the control valve from being plugged with floating material on initial backwash.

- H. Remove funnel and clean filter material from tank threads.
- I. Remove cork or tape from distributor tube.
- J. Replace control valve on mineral tank.

Caution : *Be extremely careful to position distributor tube into control valve distributor tube pilot hole.*

- 3. Turn OFF main water supply and OPEN nearest faucet to relieve pressure.
- 4. Cut main line and install appropriate elbows and extensions. Inlet connection on the A/P Tank is 1" FNPT. The outlet is 1" MPT. Inlet is in the top of the tank and outlet is out the bottom. Inlet / outlet connections on the filter bypass are 3/4" SS FNPT.

Note : An optional 1" FNPT bypass is available.

Caution : *Raised arrows located on the sides of control valve body and bypass valve indicate proper direction of water flow. Install inlet and outlet piping in direction of arrows.*

Caution : *If using PVC pipe for installation of A/P Tank, assemble inlet tee before installing on tank manifold, to prevent excess solvent from entering A/P manifold assembly. Use only Teflon based tap and paste for threaded connections!*

- 5. Turn handle of the bypass valve to the bypass position (horizontally).
- 6. Turn the main supply on to restore water service to the home.
- 7. **OPEN** nearest faucet to evacuate air and repressurize plumbing lines.
- 8. Check for leaks!

- Drain Line Connections -

- 1. Loosen screw and remove drain line assembly located on the left side of control valve. Remove drain line hose barb and wrap threads with Teflon tape. Reinstall drain line hose barb.

Caution : *Hand tighten only!!! Replace drain line assembly and tight screw.*

- 2. Install 1/2" I.D. drain line tubing (not included) from hose barb to an open drain. A 4" gap between the end of the drain line and the open drain is required to prevent waste water backflow. Keep the drain line as short as possible. An overhead drain line can be used, if necessary, but should discharge below the control valve. A syphon trap (taped loop) at the outlet of the drain line is advisable to keep the drain line full and assure correct flow during backwash. Elbows or other fittings must be kept at a bare minimum.

Note : Where the drain line is elevated above the control valve or exceeds 20' in length, 3/4" I.D. drain line tubing should be used.

- 3. Install included 3/8" x 1/4" tubing to air vent hose barb on A/P Tank Manifold and run to drain. An air gap **must** be provided.

Warning : *Do not tee air vent line to drain line or soil line. Protect air vent line from freezing.*

- Electrical Connection -

- 1. Connect the cord from the control valve and plug into a 115 volt / 60 Hz receptacle.

Note : Do not plug into an outlet controlled by a wall switch or pull chain that could inadvertently be turned off.

- When To Backwash -

Under optimum conditions, the unit should be backwashed once ever 6 days. In extreme cases where iron is at or approaches the maximum for the unit and/or water usage exceeds 300 gallons per day, the unit should backwash every 3 days. Remember, these instructions need to be tailored to your water usage and incoming water conditions. Your system may require more backwashes.

- Automatic Valve Setting 2092 Control -

The filter control valve has two dials on the front. The center dial is the largest and is called the manual backwash knob. (See Diagram 1.) To the right of the large dial is the skipper wheel used to set backwash days. The manual backwash knob should be rotated **Clockwise** only and has a notch in it through which you will be able to read the cycle names as it progresses through the backwash. **The system must be started in the "In Serv" position.**

- Starting The Unit -

Place the filter valve unit in the "In Serv" position and follow these steps :

1. Make sure the main incoming valve from the pump is closed.
2. Restore power to the well pump.
3. Slowly open the main valve and bypass. Open a faucet and let the water slowly run thru the plumbing until all air is driven from the system.
4. Turn the manual regeneration knob clockwise until you can read "**Backwash**" thru the knob notch. The tanks will be full when water runs steadily through the filter and to the drain.
5. Place the filter control valve in the "**Rinse**" position by rotating the manual backwash knob clockwise. Now open the main water valve completely. Allow the unit to rinse until the water coming from the drain is clear. Discharge all air from the lines by opening faucets. Check for leaks.

- How To Set Days Of Backwash -

Rotate the skipper wheel until the number "1" is at the red pointer. Set the days that the backwash is to occur on by sliding tabs on the skipper wheel outward to expose trip fingers. Each tab is one day. Finger at red pointer is tonight. Moving clockwise from the red point extend or retract fingers to obtain the desired backwash schedule. (See Diagram 1.) If you want to backwash every day, you would slide all the tabs out. Every other day would extend out 2, 4, 6, 8, 10, 12 (or 6 tabs). Every three days would extend tabs 3, 6, 9, 12 (or 4 tabs). Every four days would extend tabs 4, 8, 12 (or 3 tabs). Every six days would extend 6 & 12 (or 2 tabs). Every 12 days extend tab 12 only.

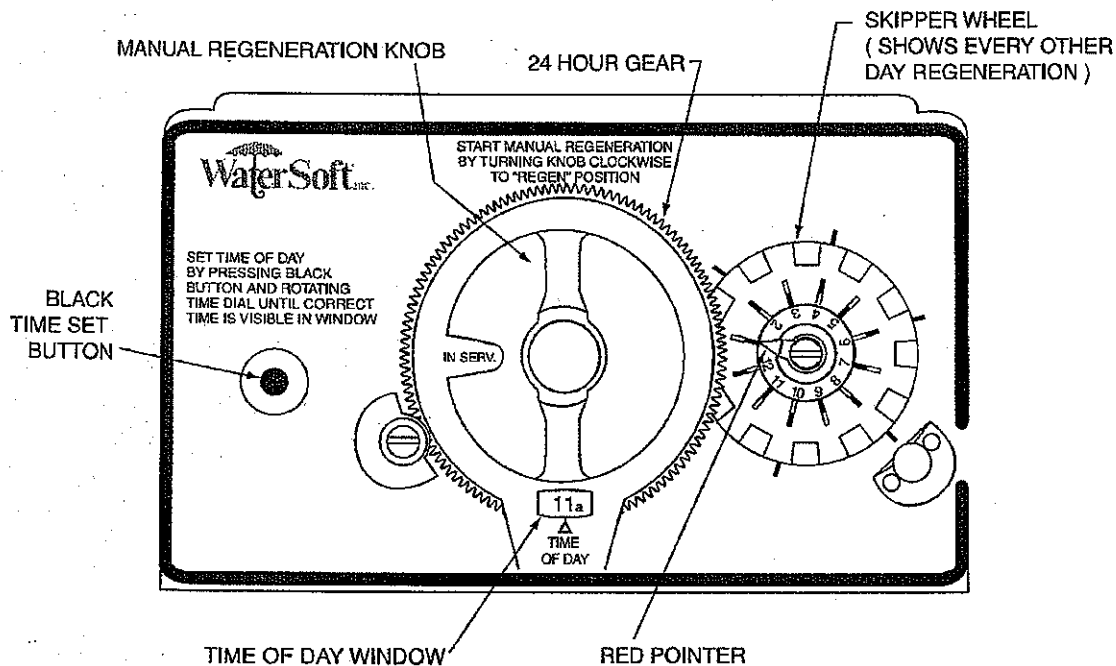

- Backwash Guideline -

This is a guideline offered to help in establishing a start point for setting the "day" intervals between backwash on PROVECTR installations.

To work the formula, you need to know three (3) variables :

1. The cubic foot capacity of the unit installed.
2. The number of people using water from the system. (This is used to set the liters per day usage.)
3. The **Total** combined contaminant's in mg/L (Iron, Manganese and/or Hydrogen Sulfide). Note that a mg/L is equal to a ppm. These numbers come from the water analysis.

The constant factor in this equation is going to be that each cubic foot of MultiBlend media is capable of removing 15,000 mg/L (or ppm) of contaminant's from the water between backwashes. If your unit has more than one cubic foot of media, multiply 15,000 by the number of cubic feet in the unit to find the removal capability.

To work the formula :

- A. Multiply the number of people by 284 liters per day (equal to about 75 gallons per person) to find the daily use (DU) in liters.
- B. Multiply daily use (DU) by the combined contaminant level (CCL) to find the contaminant level to be removed per day (RPD).
- C. Divide the constant factor of unit size you are installing ($15,000 \times \#$ of cubic feet = CF) by the removal per day (RPD) to find the days between backwashing (DAYS).

Example : You are installing an AF10P unit (1.5 cu. ft.). Water test indicates a total of 7 mg/L (ppm) of contaminant level and the family using this unit has 4 people.

- A. Four people times 284 liters = 1,136 liters per day to be treated (DU).
- B. 1,136 times 7 (CCL combined contaminant) = 7,952 required removal per day (RPD).
- C. Our unit is 1.5 cu.ft. So we have a ($1.5 \times 15,000 = 22,500$) 22,500 capacity divided by 7,952 equals 2.8 days between regeneration.

You should always round the "day" number down to fit the days timer capacity of the unit you are installing. For example, if your calculation came up with 5 days and you have a 12 day timer, you would need to set it at 4 day regeneration since a 5 day interval is not applicable.

It is also important to keep in mind that it may be necessary to make adjustments over a period of time to arrive at the correct settings.

- How To Set Time Of Day -

Press and hold the black button on the left side of the control valve in to disengage the drive gear. Turn the large gear (not the knob) in the center until the actual time of day appears in the "Time Of Day" window at the bottom. Release the black button to again engage the drive gear. Make sure the "AM" or "PM" is correct for your situation. The starting time for System 1 backwash is preset to be about 1:00 AM. The backwash and rinse cycles are also preset. (See Diagram1.)

- How To Manually Backwash -

Turn the manual backwash knob clockwise until you read "Start Cycle". The unit will automatically continue through the backwash cycle and then return to the "In Serv" position when complete.

- How To Skip Backwash -

For vacation of extended periods of absence, the timer cord plug can be pulled out of the receptacle. Upon return, plug in the timer, reset the time of day and backwashing will resume as normal.

- Final Checkout -

1. Be certain that the bypass valve is in "Service" position, if so equipped.
2. Check electrical supply to be certain the cord is connected to an uninterrupted 115 volt outlet.
3. Check that the time of day is set.
4. Double check the backwash settings.
5. Make final check for leaks.
6. Be certain the warranty card is filled out and mailed.

No.	Description	Part Number
1	Venturi Nozzle Assy.	64555C000
2	Body with Venturi	69000B101
3	Diaphragm (2) required	64555C103
4	Cap	69000B102
5	Screw (6) required	64555C108
6	Schrader Valve	64555C102

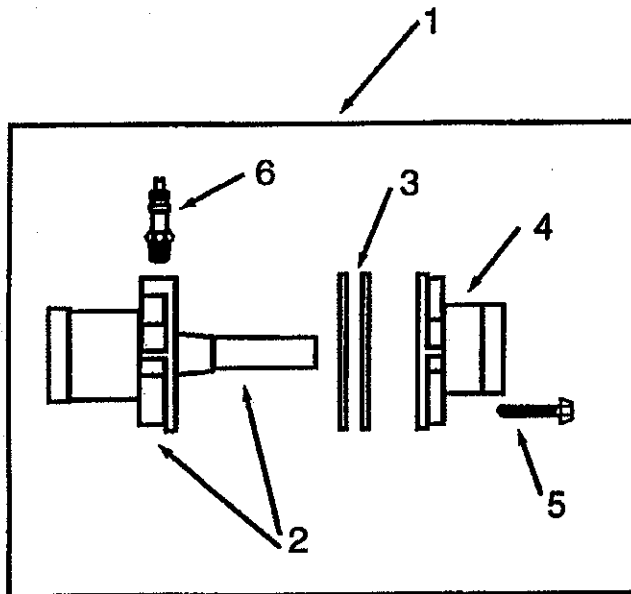

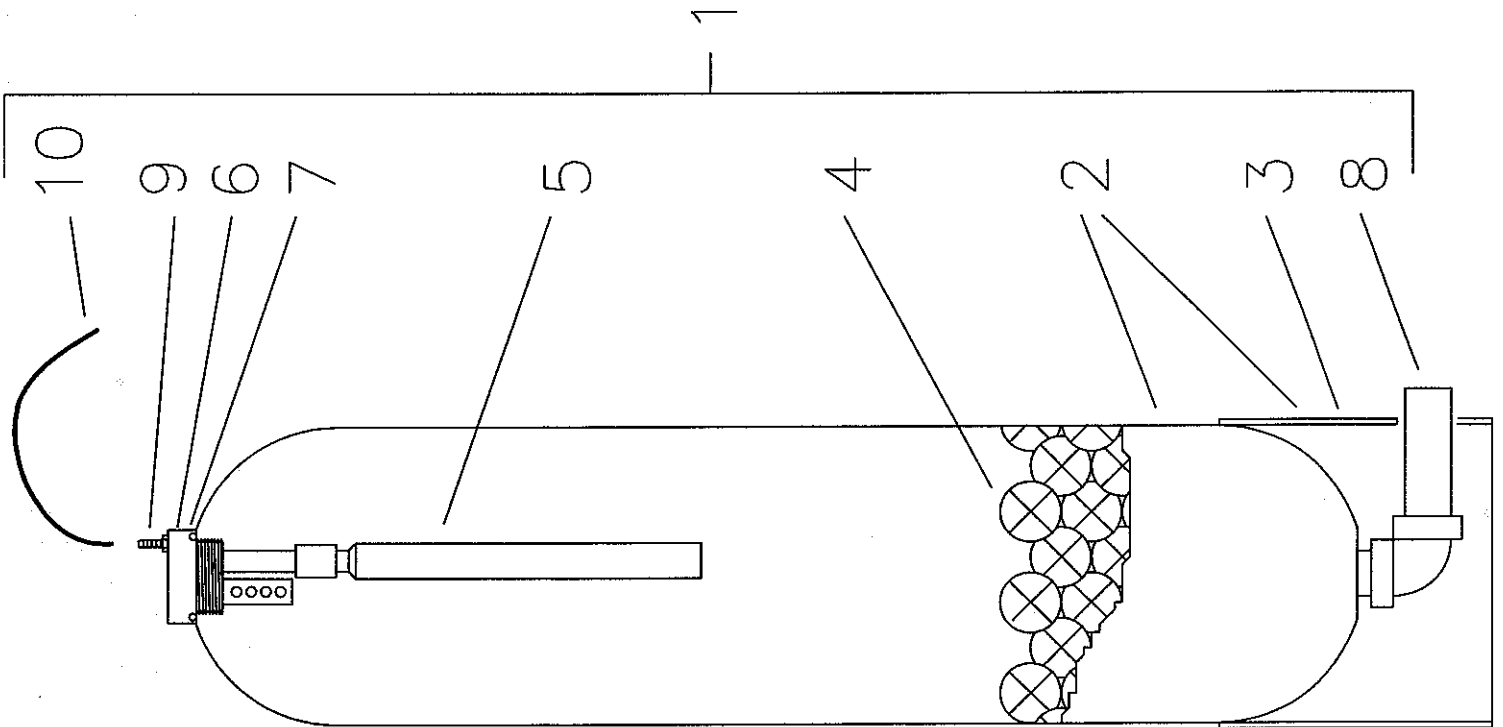

AP Tank Assembly

No.	Part No.	Description
1	63555C000	AP Tank Assy. Less Venturi 7 x 35
	63555C099	Super Size AP Tank Assy. Less Venturi 10 x 54
2	30735X101	7 x 35 Tank With Base
	31054X108	10 x 54 Tank With Base
3	N/A	Base Only
4	63555C114	Pack of 25 Aerator Balls
5	63555C103	Float Assy.
6	62128C502	Manifold With O-ring
7	65555X220	O-ring Only
8	D1288	Elbow Assy.
9	69000B110	Brass Hose Barb
10	570005X002	Vent Tubing Per Foot

Parts Diagrams

"2092" Powerhead

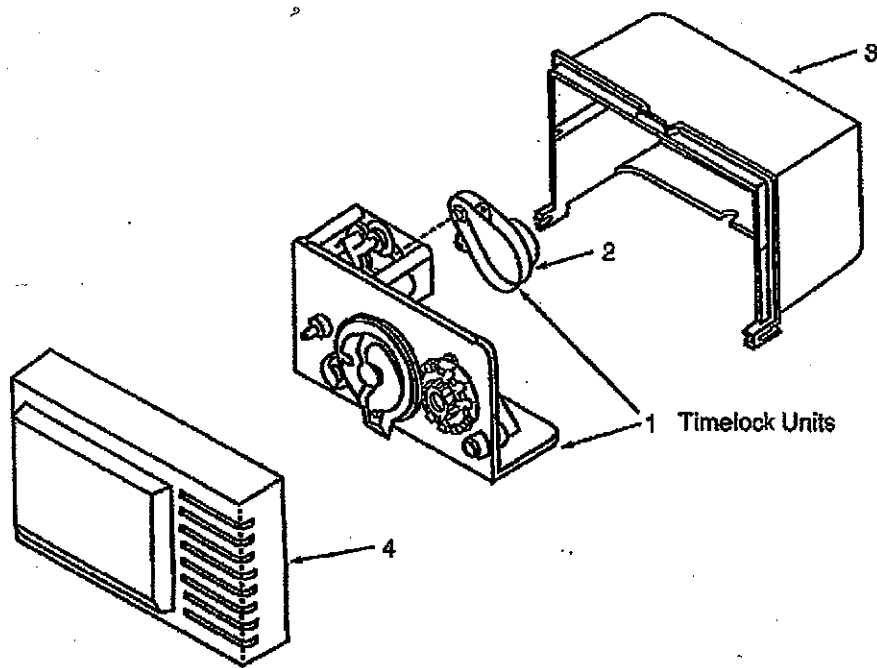

Ref. #	Part #	Description
1	20922C201	Powerhead - Filter
2	20921C203	Motor - Clock 115 VAC 60 Hz
4	20921C204	Cover - Front
3	20921C205	Cover - Rear

Parts Diagrams

"2092" Control Valves Filter Bodies

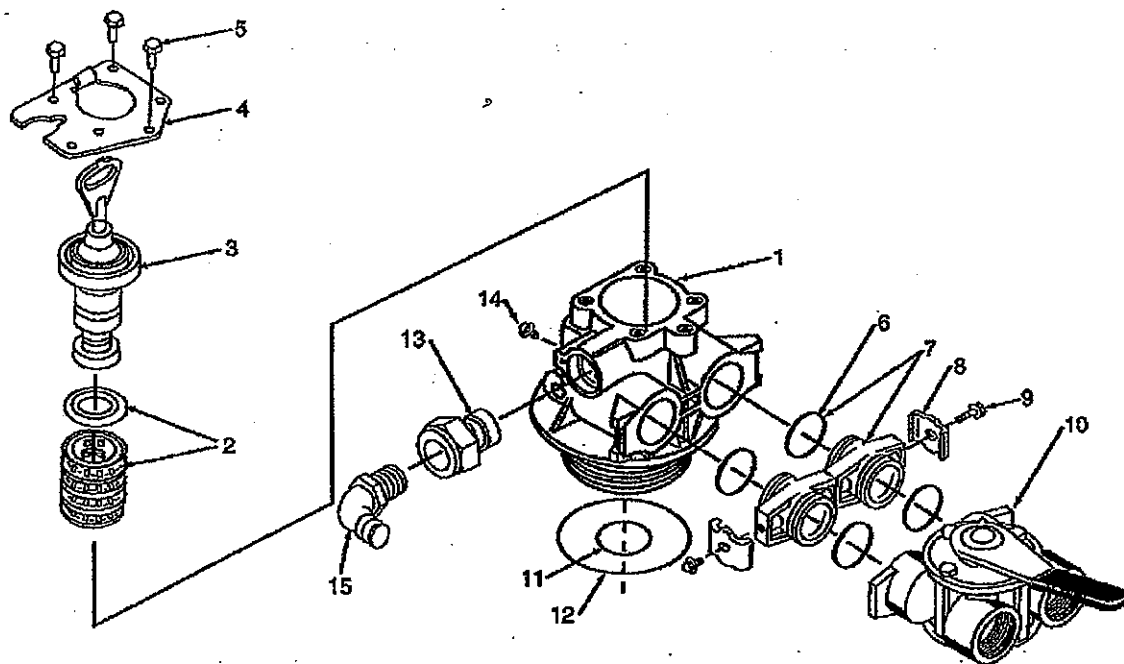

Ref #	Part #	Description
1	20922C202	Body Filter
2	20922C204	Seal & Spacer Kit
3	20922C203	Piston & End Plug Assy.
4	20561X249	Retainer End Plug
5	20561X250	Screw Hex HD 10-24 x 1/2" - 3 Req'd.
6	20561C216	O Ring - 4 Req'd.
7	20561X215	Adaptor - 2 Req'd.
8	20561X201	Clip Adaptor - 2 Req'd.
9	20561X217	Screw Gex GD 8-18 x 5/8" - 2 Req'd.

Ref. #	Part #	Description
10	20561X270	Bypass 3/4" NPT
	20561X283	Bypass 1" NPT
11	20561X204	O Ring
12	20561X205	O Ring
13	20251X262	Control Flow 5.0 GPM
	20561X264	Control Flow 7.0 GPM - Include Button & O Ring
	20251X272	Button 5.0 GPM
	20251X273	Button 7.0 GPM
	20251X254	O Ring
14	N/A	Screw 6-32 x 1/2"
15	20251X255	Elbow 1/2" NPT x 1/2" Barb



Limited Warranty Water Treatment Equipment

This warranty cannot be transferred - it is extended only to the original purchaser or first user of the product. By accepting and keeping this product, you agree to all of the warranty terms and limitations of liability described below.

(Mail your product registration card within 30 days of purchase to ensure your warranty coverage or proof of purchase will required.)

Important Warning : Read carefully the WaterSoft Water Treatment Equipment Installation, Operating and Maintenance Instructions Manual to avoid serious personal injury and property HAZARDS and to ensure safe and proper care of this product.

Model Numbers Covered

Water Softeners, Media Filters, Upflow Filters, PROTECTR's, UV, RO, Filters, Chemical Feed

*FOR AS LONG AS YOU OWN AND LIVE IN YOUR SINGLE FAMILY HOME, this warranty covers your water treatment equipment, if you are the first user of this WaterSoft water treatment equipment and purchased it for single family home use - subject to all of the conditions, limitations and exclusions listed below. Purchasers who buy the WaterSoft water treatment equipment for other purposes, and other component parts are subject to more limited warranties and you should read all of the terms included in this form to make sure you understand your warranty.

What is covered by this warranty?

WaterSoft warrants that at the time of manufacture, the water treatment equipment shall be free from defects in material and workmanship as follows :

Thermoplastic Mineral Tanks.....	10 years
Softener/Filter Control Valves.....	5 years
Brine Tank Assemblies.....	3 years
Chemical Feed Pumps.....	1 year
Reverse Osmosis System.....	1 year
Other Accessories & Parts.....	1 year

* This warranty does not include media and/or cartridge filter elements.

Additional Terms & Conditions

What WaterSoft will do if you have a covered warranty claim
WaterSoft will at its option either make repairs to correct any defect in material or workmanship or supply and ship either new or used replacement parts or products. WaterSoft will not accept any claims for labor or other costs.

Additional Exclusions and Limitations

This warranty is non-transferable and does not cover any failure or problem unless it was caused solely by a defect in material or workmanship. In addition, this warranty shall not apply :

- if the water treatment equipment is not correctly installed, operated, repaired and maintained as described in the Installation, Operating & Maintenance Instructions Manual provided with the product.
- if the tank is not the size indicated for the supply line size of the installation, as described in the manual.
- if the unit has not always been operated within the factory calibrated temperature limits, and at a water pressure not

- exceeding 125 psi.
- to any failure or malfunction resulting from abuse (including freezing), improper or negligent handling, shipping (by anyone other than WaterSoft), storage, use, operation, accident, or alteration, lightning, flooding or other environmental conditions;
- to any failure or malfunction resulting from failure to keep the unit full of potable water, free to circulate at all times; and with the tank free of damaging water sediment or scale deposits;
- this warranty does not cover labor costs, shipping charges, service charges, delivery expenses, property damage, administrative fees or any costs incurred by the purchaser in removing or reinstalling the water treatment equipment.
- the warranty does not cover any claims submitted to WaterSoft more than 30 days after expiration of the applicable warranty, and does not apply unless prompt notice of any claim is given to an authorized WaterSoft distributor or to WaterSoft or a designated contractor is provided access to the installation and to the water treatment equipment.

THESE WARRANTIES ARE GIVEN IN LIEU OF ALL OTHER EXPRESS WARRANTIES. NO WATER SOFT REPRESENTATIVE OR ANY OTHER PARTY IS AUTHORIZED TO MAKE ANY WARRANTY OTHER THAN THOSE EXPRESSLY CONTAINED IN THIS WARRANTY AGREEMENT.

Additional Warranty Limitations

ANY IMPLIED WARRANTIES THE PURCHASER MAY HAVE, INCLUDING THE IMPLIED WARRANTIES OF MERCHANTABILITY AND FITNESS FOR A PARTICULAR PURPOSE, SHALL NOT EXTEND BEYOND THE APPLICABLE TIME PERIODS SPECIFIED ABOVE. Some states do not allow limitations on how long an implied warranty lasts, so the above limitations may not apply to you.

Limitations of Remedies

The remedies contained in this warranty are the purchaser's exclusive remedies. In no circumstances will WaterSoft or the seller of the product be liable for more than, and purchaser-user's remedies shall not exceed, the price paid for the product. In no case shall WaterSoft or seller be liable for any special, incidental, contingent or consequential damages. Special, incidental, contingent and consequential damages for which WaterSoft is not liable include, but are not limited to, inconvenience, loss or damage to property, consequential mold damage, loss of profits, loss of savings or revenue, loss of use of the products or any associated equipment, facilities, buildings or services, downtime, and the claims of third parties including customers. Some states do not allow the exclusion or the limitation of incidental or consequential damages, so the above limitations or exclusion may not apply to you.

What to do if you have a problem covered by this warranty

Any warranty coverage must be authorized by WaterSoft. Contact the person from whom you purchased the product, who **must** receive authorization from a WaterSoft distributor or WaterSoft. If you do not receive a prompt response, call WaterSoft directly at 800-462-3790. Notice of a warranty claim relating to replacement parts or products should be submitted by the authorized distributor to WaterSoft at the following address :
WaterSoft Inc., Warranty Claim Dept., 710 Orange St., Ashland, OH 44805

If your product is new and not used and you wish to return it, contact your WaterSoft distributor.