



Installation / Operation Manual

Demand Regeneration Water Softener

Isobar Control Valve

For Model Numbers :

- | | |
|---------------------------------------|--|
| <input type="checkbox"/> CD24P | <input type="checkbox"/> CD24VP |
| <input type="checkbox"/> CD32P | <input type="checkbox"/> CD32VP |
| <input type="checkbox"/> DS24P | <input type="checkbox"/> DS24VP |
| <input type="checkbox"/> DS32P | <input type="checkbox"/> DS32VP |
| <input type="checkbox"/> DS48P | <input type="checkbox"/> DS48VP |
| <input type="checkbox"/> DS64P | <input type="checkbox"/> DS64VP |
| | <input type="checkbox"/> DS96VP |

Installation Requirements

- A level floor position ahead of piping into water heater.
- Unit must be installed at least 10' ahead of the inlet to the water heater to prevent damage due to back-up of hot water.
- DO NOT install the unit in an area of direct sunlight or where freezing temperatures may occur! (See Installation Diagrams for proper placement and plumbing connections.)

Major System Components :

1. **Brine Tank** - This tank holds the salt that is added to the softener. This salt is dissolved with water to form a brine solution used in the softener regeneration process.
2. **Resin Tank** - This tank contains the ion exchange resin material. Water flows through the resin tank under pressure to come into contact with the resin for water softening.
3. **Control Valve** - The valve directs water through the resin tank for water softening and controls the flow of water/brine for the regeneration process.

Typical Cabinet Model

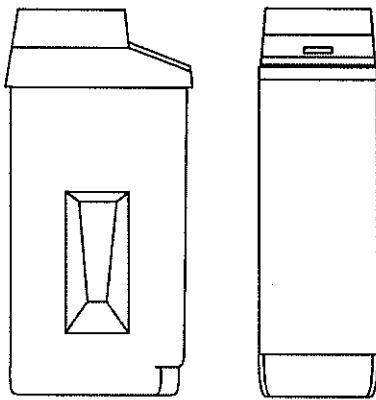

Typical Two Tank Model

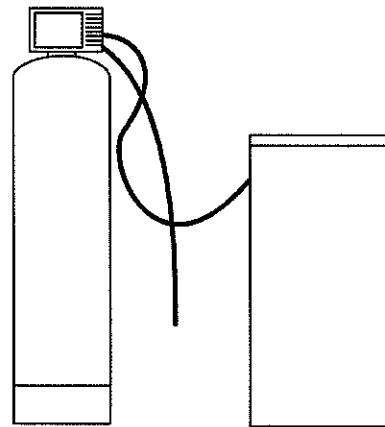

Typical Installations

(Water incoming from LEFT side)

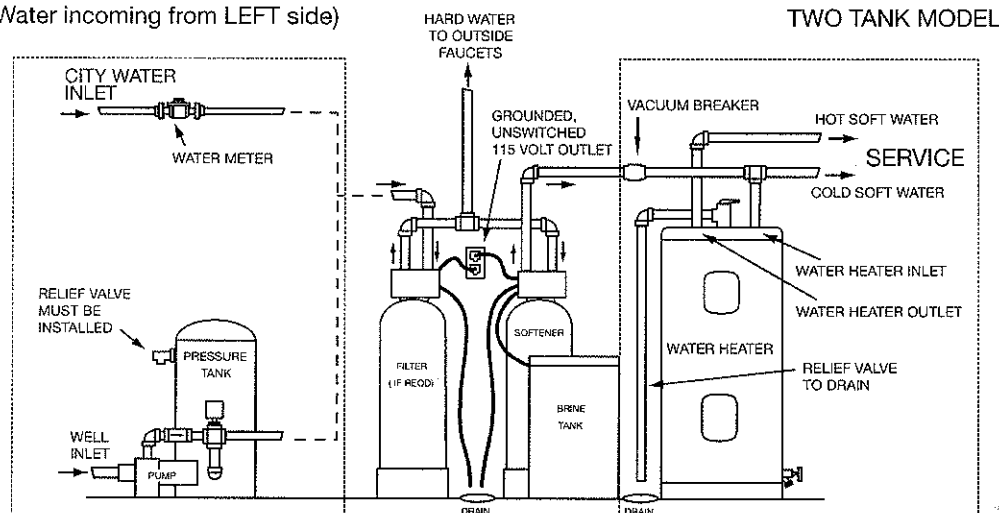

For illustration only, adhere to all local and state codes.

Installation Requirements

(Water incoming from RIGHT side)

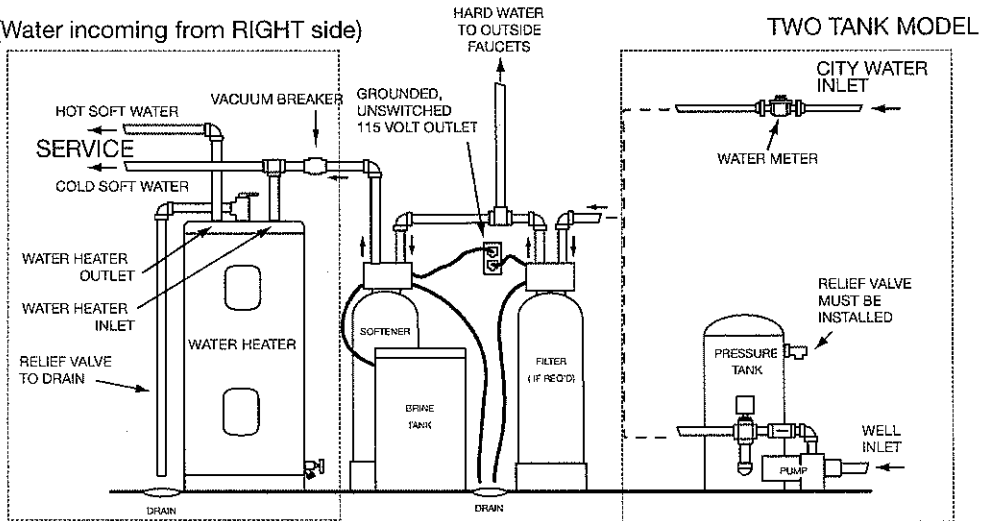

(Water incoming from LEFT side)

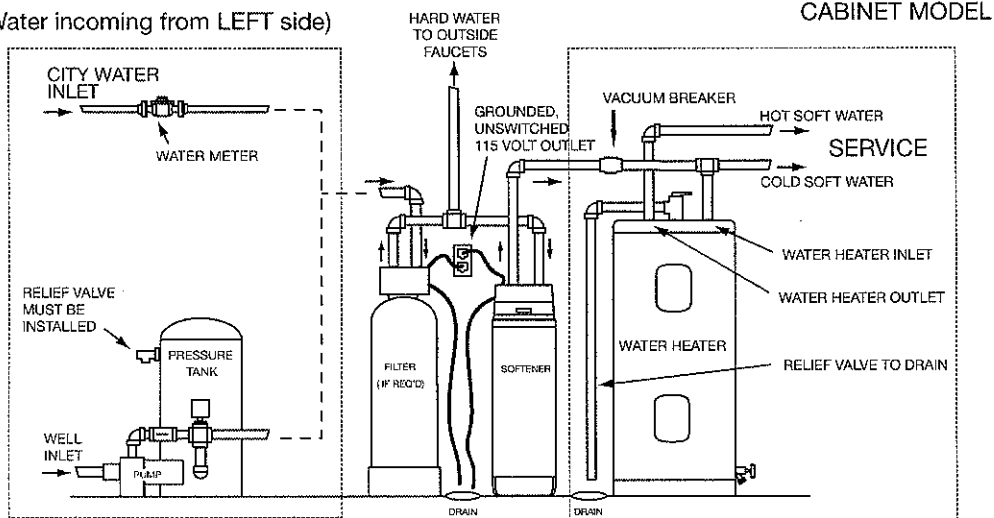

(Water incoming from RIGHT side)

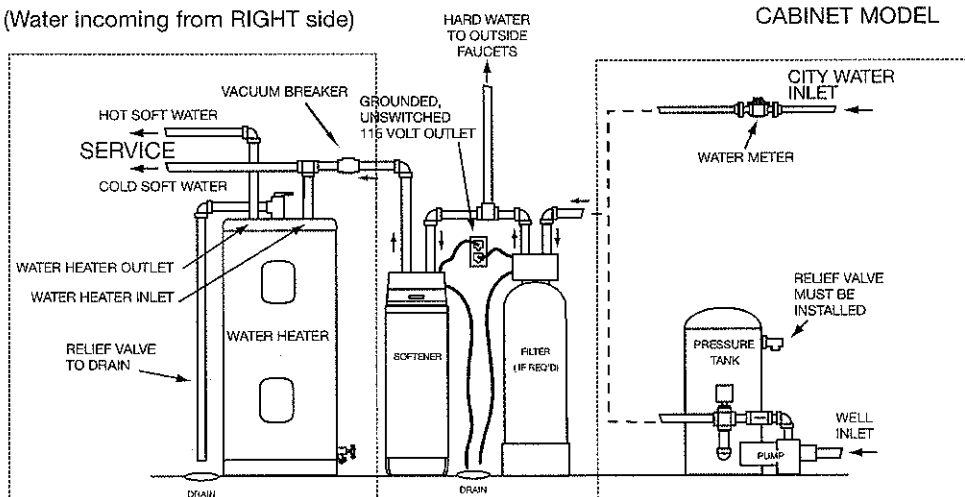

For illustration only, adhere to all local and state codes.

Softener Location / Other Requirements

- Locate the unit near an unswitched, 120 volt / 60 Hz grounded electrical outlet.
- Check for distance and proper drain installation (e.g. floor drain, washing machine, standpipe).
- Determine type and size of piping required for softener connection (e.g. copper, galvanized, PVC plastic).

Note : If household plumbing is galvanized and you intend to make the installation with copper (or vice versa), obtain di-electric unions to prevent dissimilar metal corrosion.

Note : Where the drain line is elevated above the control valve or exceeds 20 feet in length to reach the drain, use 3/4" I.D. drain line tubing instead of 1/2" I.D. Drain line tubing is not included.

Caution : *If sweat soldering copper pipe : (Remember to always use lead free solder and flux.) Cover yoke or bypass valve with wet rags to prevent heat damage to connections and control valve?! If using PVC or plastic pipe, primers and solvent cements specifically recommended for use with potable water are required.*

Installation Procedure

- Water Supply Connections and Bypass Valve -

To allow for softener servicing, swimming pool filling or lawn sprinkling, a manual Bypass Valve has been installed at the factory. The Bypass Valve allows hard water to be manually routed around the softener.

1. Position softener at desired location for installation. (See Installation Diagrams.)
2. Turn OFF main water supply and OPEN nearest faucet to relieve pressure.
3. Cut main line and install appropriate elbows and extensions. Inlet and outlet connections on the bypass are 3/4" FPT pipe size.

Note : An optional 1" bypass is available.

Caution : *White arrows located on the sides of control valve body and bypass valve indicate proper direction of water flow. Install inlet and outlet in directions of arrows.*

4. Rotate the handle on the bypass valve to the bypass position. The handle will be horizontal with the plumbing lines.
5. Turn the main supply line on to restore water service to the home.
6. OPEN nearest faucet to evacuate air and repressurize plumbing lines.
7. Check for leaks!!!

- Drain Line Connection -

1. Remove drain line hose barb located on back right side of control valve. Wrap threads of hose barb with Teflon tape. Reinstall drain line hose bard **CAUTION : Hand tighten only!!**
2. Install 1/2" I.D. drain line tubing (not included) from hose barb to an open drain. A 4" air gap between the end of the drain line and open drain is required to prevent waste water backflow. Keep the drain line as short as possible. An overhead drain line can be used if necessary but should discharge below the control valve. A siphon trap (taped loop) at the outlet of the drain line is advisable to keep the drain line full and assure correct flow during regeneration. Elbows or other fittings must be kept at a bare minimum.

Note : Where the drain line is elevated above the control valve or exceeds 20' in length, 3/4" I.D. drain line tubing should be used.

- Brine Line and Overflow Connection -

1. Position brine tank on a smooth level surface near the softener resin tank. If necessary, the brine tank can be placed at a higher level than the resin tank, but **never at a lower level**. (See Installation Diagrams.)
2. Install one end of 3/8" O.D. by 1/4" I.D. brine line tubing (included with units) to compression fitting located on right side of control valve.
3. Remove brine tank cover or salt compartment lid.
4. Remove cap from brine well.
5. Insert opposite end of brine line through outer hole in brine tank. On cabinet models, insert tubing through hole in brine well.
6. Connect brine line to compression fitting on safety brine valve located inside brine well.
7. Install 1/2" I.D. drain line tubing (not included) to the overflow fitting on brine tank just below the brine line. Located on side of unit for cabinet models.
8. Run the opposite end of brine tank drain line to a suitable drain.

Note : The brine tank drain line is gravity flow and must discharge below the overflow fitting.

Caution : **Do not "TEE" to the main drain line from control valve.**

Notice : The brine overflow is provided as a back-up in the event the safety float shut-off should fail, allowing the brine tank to overflow. This drain connection would then carry the excess water to the drain and prevent flooding of the floor. Therefore, no liability will or can be assumed by the manufacturer of the softener should this occur.

- Electrical Connection -

1. Plug the cord from the control valve into a standard 115 volt / 60 Hz receptacle.

Note : DO NOT plug into an outlet controlled by wall switch or pull chain that could inadvertently be turned off.

2. For your protection, this unit is equipped with a 3-prong plug and should be plugged into a grounded receptacle. If the receptacle is designed only to accept 2-prong plugs, obtain a 3-prong adapter and secure the ground wire to the receptacle plate mounting screw.

Warning: DO NOT remove grounding plug! An improperly grounded unit could cause injury from electric shock!

- Pressurizing The System -

1. Remove control valve cover or cabinet lid to access control panel. (See Figure 1.)
2. The control valve **must be started in the SERVICE position!!** The word SERVICE is imprinted in the notch on the manual regeneration knob. (See Figure 1.) IF needed, rotate the manual regeneration knob CLOCKWISE to this position.

Warning : NEVER turn regeneration knob counter clockwise as this will cause damage to the control valve!

3. Slowly turn the handle of the bypass valve to the SERVICE position. The handle will be parallel with the plumbing lines.
4. Open the nearest faucet to evacuate air from plumbing lines.
5. Check for leaks!!

- Control Valve Operation -

Each control valve position can be manually selected by rotating the regeneration knob CLOCKWISE until the desired position appears in the knob notch.

1. Manually index regeneration knob to BACKWASH position and allow water to run to drain for 3 - 4 minutes.
2. Manually index regeneration knob to BRINE REFILL position and allow the brine tank to fill just over the salt grid plate.

3. Manually index regeneration knob to BRINE & RINSE position and allow the control valve to draw water from the brine tank until it stops.
4. Manually index regeneration knob to SERVICE position.

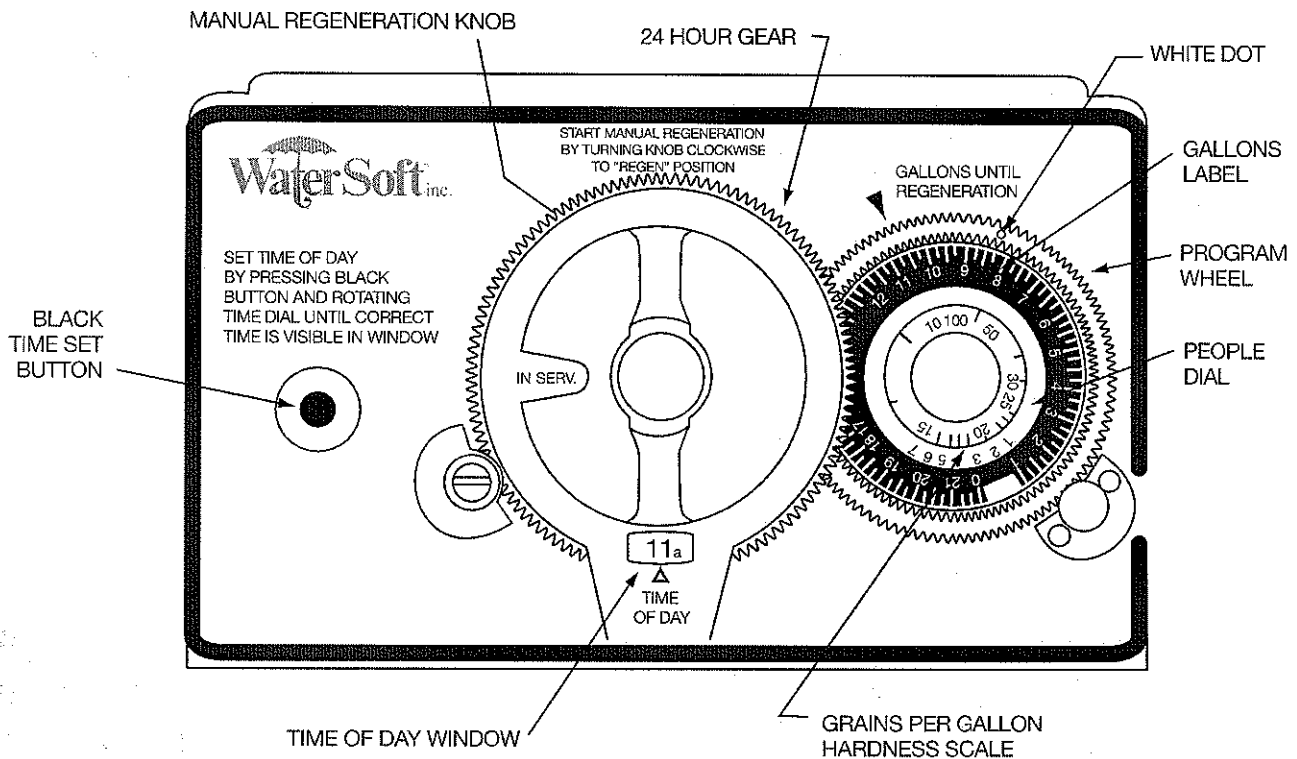

- Setting The Regeneration Schedule -

1. Locate the program wheel just to right of the manual regeneration knob.
2. Rotate program wheel until the white dot located on the outermost gear is aligned with the capacity (gallons) arrow on the control panel.
3. Place your thumb firmly on the white dot to hold the outer gear while setting the program wheel.
4. Lift out the "people" dial and rotate it so that the number of people in the family is aligned with the compensated hardness in grains per gallon. The capacity arrow will not be aligned to the gallons of water that will be used between each regeneration as shown on the gallons label located outside the "people" dial. If preferred, the unit can be set by gallons using this procedure. To calculate gallons, divide the grain capacity of the unit by the compensated hardness level. It is then advisable to subtract one day of water usage to provide a reserve. This setting will assume ample soft water for the family and automatically set a reserve capacity into the system.
5. Push the meter cable firmly into the meter module on the back of the control valve.

Note : Salt settings are pre-set at the factory for the maximum shown on the capacity chart. Salt settings should never be reduced on Demand Regeneration systems as a different volume of reserve capacity will be used before each regeneration. If the water contains iron and / or manganese, multiply the total parts per million (ppm) by four (4) and then add to the grains per gallon (gpg) of hardness. Use this compensated hardness level when programming the regeneration frequency.

Warning: *DO NOT* reduce salt setting below 9 lbs. as the water level in the brine tank will not reach the grid plate.

- Setting The Time Of Day -

1. Depress the black button on left side of valve control panel.
2. Rotate the 24 hour gear on the manual regeneration knob until the time of day appears in the window. (Note a.m. and p.m.)
3. Check that black button has engaged in the 24 hour gear.
4. The starting time for regeneration is factory pre-set to occur at 2:00 a.m.

Note : If a different time is desired, set the time of day ahead or behind the actual time of day. If this is done, it is recommended that the time dial be re-labeled.

Start-Up Procedure

The material used in the construction of the modern water softener will not support the growth of bacteria. However, the conditions existing during shipment, storage and installation are unknown and thus dictates the disinfecting of a softener after installation, before it is used to treat potable water. With this in mind, your newly installed water softener should be disinfecting using the recommended procedure described in this section. Ordinary chlorine laundry bleach is an excellent disinfecting agent for this purpose. The proper dosage for your particular softener model is listed below.

Figure 5

Unit Capacity	Cubic Feet of Resin	Chlorine Dosage
24,000	0.175	.9 ounces
32,000	1.00	1.2 ounces
48,000	1.50	1.8 ounces
64,000	2.00	2.4 ounces
96,000	3.00	3.6 ounces

1. Measure proper amount of chlorine bleach as shown above.
2. Pour the chlorine directly into brine well located inside brine tank or cabinet.
3. Replace brine well cap.

- Filling The Brine Tank With Salt -

To expect a high level of performance and reliability, a salt manufactured specifically for water softeners must be used. Salt of this grade is virtually free from dirt and other particulates that would eventually cause the softener to malfunction. A pellet type salt is recommended although any high quality water softener salt (such as solar salt) will suffice. If iron is present in the raw water, use of iron inhibiting salt is recommended. The salt level will decrease after each regeneration cycle. Consequently, the salt compartment will need to be checked and replenished periodically.

1. Fill the brine tank or cabinet with water softener salt as described above. This will be approximately 250 lbs. of salt.

Warning : Do not fill salt above level of the brine well.

2. Replace brine tank or salt compartment lid.
3. Rotate manual regeneration knob CLOCKWISE to the "BRINE REFILL" position.
4. Close control valve cover or replace cabinet lid.

- Final Check -

1. Be certain the bypass valve is in the SERVICE position.
2. Make sure the electric cord is connected to an uninterrupted 115 volt outlet.
3. Check that the time of day is set.
4. Double check regeneration schedule.
5. Make final check for leaks!
6. Fill out and mail warranty card.
7. Leave this manual with the unit.

Operation, Care and Cleaning

- Operation Of Bypass Valve -

When the handle on the bypass valve is in the SERVICE position. It will be parallel with the plumbing lines, water is directed through the water softener. Water may be bypassed by turning the handle to the BYPASS horizontally. Water to the home will bypass the softener and be "untreated".

You should manually bypass the softener if :

1. The outside lines do not bypass the water softener and water is to be used for lawn sprinkling or other similar uses.
2. Servicing the water softener.
3. A water leak from the water softener is evident.
4. *Shock Treating* water well and piping with chlorine or other disinfectant.

- Extra Regeneration -

If soft water demands are unusually heavy, an extra regeneration can be initiated manually :

1. Remove the control valve face cover or remove cabinet lid to access control panel.
2. Rotate manual regeneration knob CLOCKWISE until REGEN appears in knob notch.

Caution : *DO NOT rotate regeneration knob COUNTER CLOCKWISE, as this will cause damage to the control valve! If the REGEN position is passed, continue around to SERVICE position and start again.*

3. Regeneration will begin immediately and the softener will automatically return to the SERVICE position.

Note : Water will not start flowing for several minutes.

4. Replace control valve face cover or replace cabinet lid.

- General Care and Cleaning -

1. Do not place heavy or sharp objects on water softener or cabinet.
2. Use only mild soap and warm water to clean exterior of the unit. Never use harsh, abrasive cleaners.
3. Protect the water softener and drain line from freezing.
4. Reset the time of day on the control valve after any interruption of the electrical power occurs in order to keep the unit on the proper regeneration schedule. Also, reset time for daylight savings time periods.
5. Inspect and clean the brine tank when sediment appears in the bottom of the salt compartment.
6. Always keep the brine tank supplied with good quality salt, a type designed for use in water softeners.

Servicing Instructions

- Changing The Salt -

1. Unplug electrical cord from outlet.
2. Remove the control valve back cover.
3. Locate salt dosage cam.
4. Loosen salt dosage cam set screw.
5. Rotate salt dosage cam until pointer lines up with desired salt setting.
6. Tighten set screw.
7. Replace control valve back cover.
8. Plug electrical cord into outlet.
9. Rest time of day.

Parts Diagrams

"2092" Powerhead

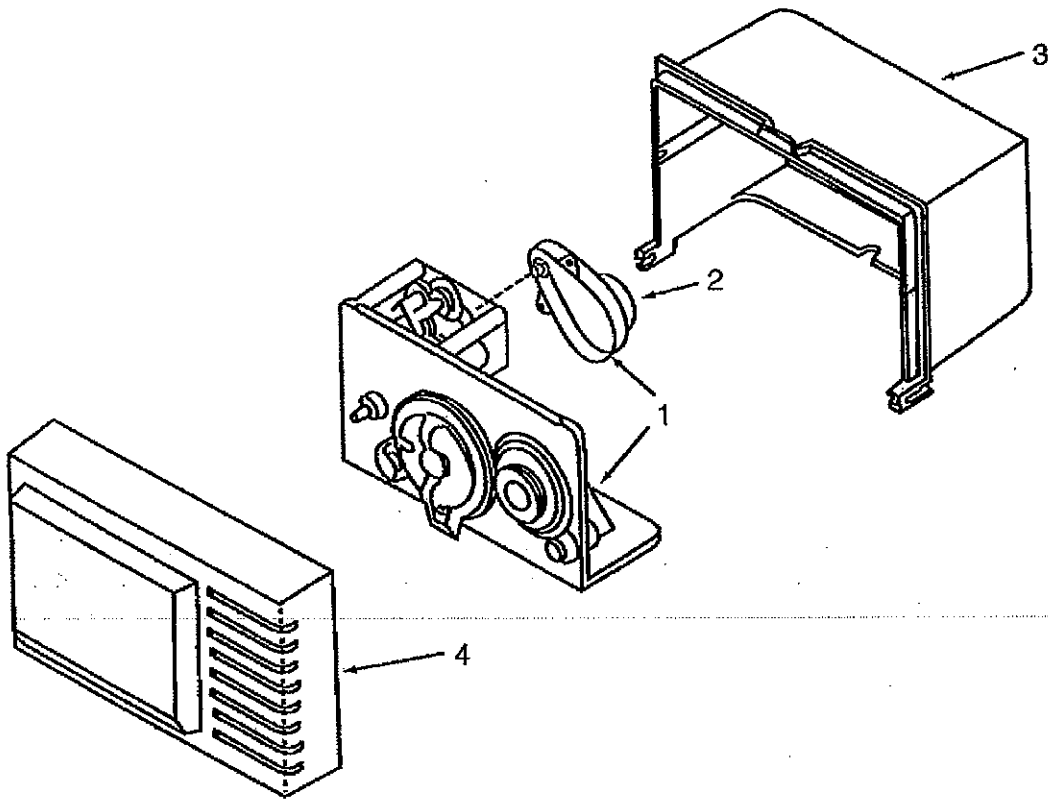

Ref. #	Part #	Description
1	20923C201 20921C201	Powerhead - Demand Softener Units (DS) Powerhead - Timeclock Softener Units (AS)
2	20921C203	Motor - Clock 115 VAC 60 Hz
3	20921C205	Cover - Rear
4	20921C204	Cover - Front (Not used on Cabinet Models)

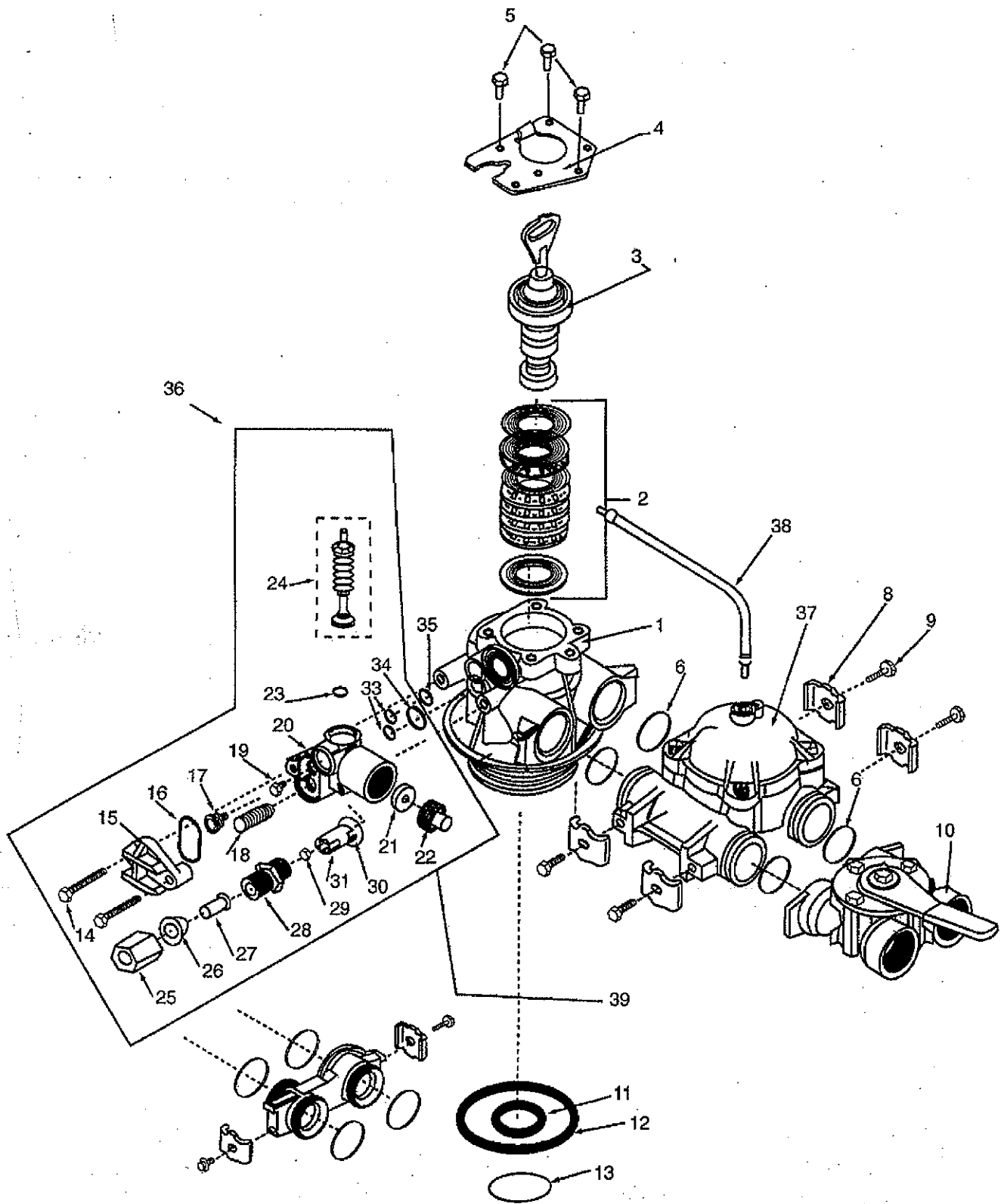

**"2092" Isobar Softener Control Valve
Valve Body Parts List**

Ref #	Part Number	Part Description	Qty. Req'd.
1	20561X203	Body - Softener	1
2	20561X253	Seal & Spacer Kit	1
3	20561X254	Piston & End Plug Assy.	1
4	20561X249	Retainer - End Plug	1
5	20561X250	Screw - Hex Hd. 10-24 x 1/2"	3
6	20561X216	O Ring - Bypass Adaptor	4
7	20561X215	Bypass Adaptor (Automatic only)	1
	Not req'd. on demand units	Bypass Adaptor	
8	20561X201	Clip - Bypass Adaptor	4
9	20561X217	Screw - 8-18 x 5/8"	4
10	20561X270	Bypass - 3/4" NPT	1
	20561X283	Bypass - 1" NPT	1
11	20561X204	O Ring - Dist. Tube	1
12	20561X205	O Ring - Valve to Tank	1
13	20251X454	Retainer Ring	1
14	20561X214	Screw - Injector Mounting	2
15	20561X226	Injector Cover	1
16	20561X221	O Ring - Injector Cover	1
17	20251X205	Inj. Nozzle # 1 White	1
	20251X241	Inj. Nozzle # 2 Blue (64k only)	1
	20251X235	Inj. Nozzle # 2 PVC (-IP units only)	1
18	20251X204	Injector Screen	1
19	20251X206	Inj. Venturi # 1 White	1
	20251X242	Inj. Venturi # 3 Blue (64k only)	1
	20251X236	Inj. Venturi # 2 PVC (-IP units only)	1
20	20561X222	Injector Body	1
21	20251X275	1.2 GPM Flow Control Button	1
	20251X266	1.5 GPM Flow Control Button	1
	20251X268	2.4 GPM Flow Control Button	1
	20251X267	2.0 GPM Flow Control Button	1
	20251X270	3.5 GPM Flow Control Button	1
	20251X272	5.0 GPM Flow Control Button	1
	20251X274	6.0 GPM Flow Control Button	1
22	20561X246	Retainer - Drain Line Flow Button	1
23	20561X220	O Ring - Brine Spacer	1
24	20561X225	Brine Valve Assy.	1
25	20251X304	Nut - Compression for Brine Line	1
26	20251X305	Ferrule - Brine Line	1
27	20251X303	Sleeve - Brine Line	1
28	20561X241	Fitting - Brine Line	1
29	20251X318	Button - .5 GPM BLFC	1
30	20561X239	O Ring - BLFC	1
31	20561X240	Retainer - BLFC	1
33	20561X219	O Ring - Injector	2
34	20561X218	O Ring - Drain	1
35	20561X248	Air Dispenser	1
36	20561X260	Specify # Inj. & DLFC	1
37	20563X200	Meter Assy.	1
38	20563X141	Cable, Meter, 8.25"	1
39	20561X256	Straight Hose Barb (Not shown)	1

Assembly Guide For 474 Safety Brine Valve System

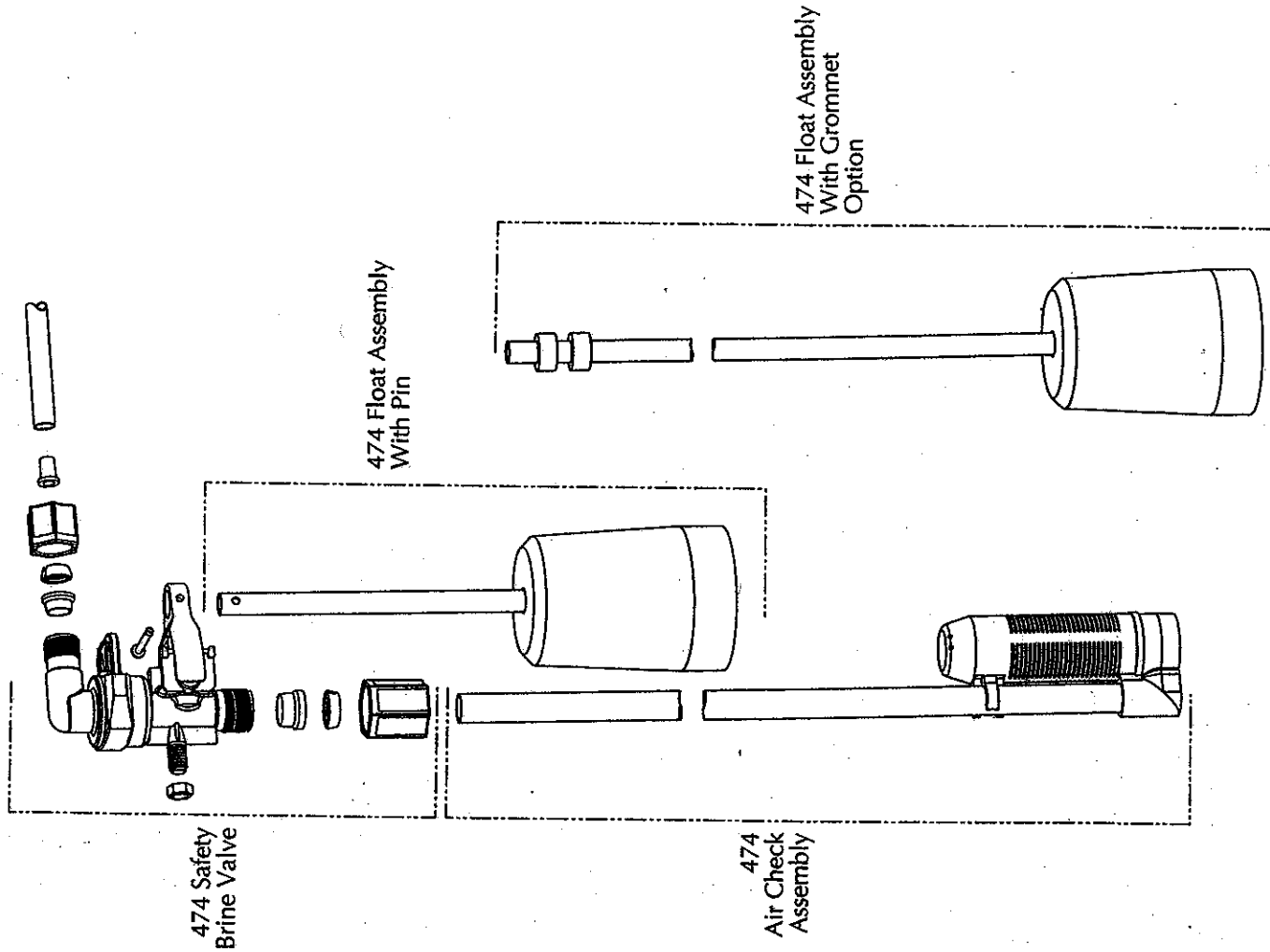

If GFN Nut Assembly is unassembled, follow these steps

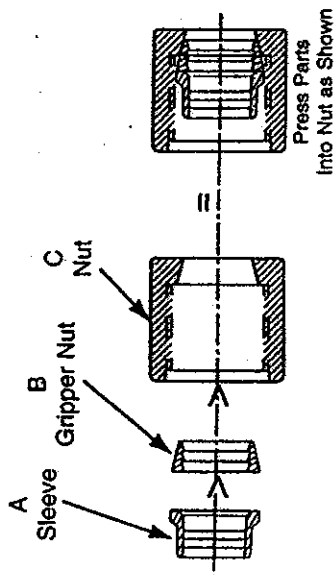



Limited Warranty Water Treatment Equipment

This warranty cannot be transferred - it is extended only to the original purchaser or first user of the product. by accepting and keeping this product, you agree to all of the warranty terms and limitations of liability described below.

(Mail your product registration card within 30 days of purchase to ensure your warranty coverage or proof of purchase will required.)

Important Warning : Read carefully the WaterSoft Water Treatment Equipment Installation, Operating and Maintenance Instructions Manual to avoid serious personal injury and property HAZARDS and to ensure safe and proper care of this product.

Model Numbers Covered

Water Softeners, Media Filters, Upflow Filters, PROVECTR's, UV, RO, Filters, Chemical Feed

*FOR AS LONG AS YOU OWN AND LIVE IN YOUR SINGLE FAMILY HOME, this warranty covers your water treatment equipment, if you are the first user of this WaterSoft water treatment equipment and purchased it for single family home use - subject to all of the conditions, limitations and exclusions listed below. Purchasers who buy the WaterSoft water treatment equipment for other purposes, and other component parts are subject to more limited warranties and you should read all of the terms included in this form to make sure you understand your warranty.

What is covered by this warranty?

WaterSoft warrants that at the time of manufacture, the water treatment equipment shall be free from defects in material and workmanship as follows :

Thermoplastic Mineral Tanks.....	10 years
Softener/Filter Control Valves.....	5 years
Brine Tank Assemblies.....	3 years
Chemical Feed Pumps.....	1 year
Reverse Osmosis System.....	1 year
Other Accessories & Parts.....	1 year

* This warranty does not include media and/or cartridge filter elements.

Additional Terms & Conditions

What WaterSoft will do if you have a covered warranty claim
WaterSoft will at its option either make repairs to correct any defect in material or workmanship or supply and ship either new or used replacement parts or products. WaterSoft will not accept any claims for labor or other costs.

Additional Exclusions and Limitations

This warranty is non-transferable and does not cover any failure or problem unless it was caused solely by a defect in material or workmanship. In addition, this warranty shall not apply :

- if the water treatment equipment is not correctly installed, operated, repaired and maintained as described in the Installation, Operating & Maintenance Instructions Manual provided with the product.
- if the tank is not the size indicated for the supply line size of the installation, as described in the manual.
- if the unit has not always been operated within the factory calibrated temperature limits, and at a water pressure not

exceeding 125 psi.

- to any failure or malfunction resulting from abuse (including freezing), improper or negligent, handling, shipping (by anyone other than WaterSoft), storage, use, operation, accident, or alteration, lightning, flooding or other environmental conditions;
- to any failure or malfunction resulting from failure to keep the unit full of potable water, free to circulate at all times; and with the tank free of damaging water sediment or scale deposits;
- this warranty does not cover labor costs, shipping charges, service charges, delivery expenses, property damage, administrative fees or any costs incurred by the purchaser in removing or reinstalling the water treatment equipment.
- the warranty does not cover any claims submitted to WaterSoft more than 30 days after expiration of the applicable warranty, and does not apply unless prompt notice of any claim is given to an authorized WaterSoft distributor or to WaterSoft or a designated contractor is provided access to the installation and to the water treatment equipment.

THESE WARRANTIES ARE GIVEN IN LIEU OF ALL OTHER EXPRESS WARRANTIES. NO WATER SOFT REPRESENTATIVE OR ANY OTHER PARTY IS AUTHORIZED TO MAKE ANY WARRANTY OTHER THAN THOSE EXPRESSLY CONTAINED IN THIS WARRANTY AGREEMENT.

Additional Warranty Limitations

ANY IMPLIED WARRANTIES THE PURCHASER MAY HAVE, INCLUDING THE IMPLIED WARRANTIES OF MERCHANTABILITY AND FITNESS FOR A PARTICULAR PURPOSE, SHALL NOT EXTEND BEYOND THE APPLICABLE TIME PERIODS SPECIFIED ABOVE. Some states do not allow limitations on how long an implied warranty lasts, so the above limitations may not apply to you.

Limitations of Remedies

The remedies contained in this warranty are the purchaser's exclusive remedies. In no circumstances will WaterSoft or the seller of the product be liable for more than, and purchaser-user's remedies shall not exceed, the price paid for the product. In no case shall WaterSoft or seller be liable for any special, incidental, contingent or consequential damages. Special, incidental, contingent and consequential damages for which WaterSoft is not liable include, but are not limited to, inconvenience, loss or damage to property, consequential mold damage, loss of profits, loss of savings or revenue, loss of use of the products or any associated equipment, facilities, buildings or services, downtime, and the claims of third parties including customers. Some states do not allow the exclusion or the limitation of incidental or consequential damages, so the above limitations or exclusion may not apply to you.

What to do if you have a problem covered by this warranty

Any warranty coverage must be authorized by WaterSoft. Contact the person from whom you purchased the product, who **must** receive authorization from a WaterSoft distributor or WaterSoft. If you do not receive a prompt response, call WaterSoft directly at 800-462-3790. Notice of a warranty claim relating to replacement parts or products should be submitted by the authorized distributor to WaterSoft at the following address :
WaterSoft Inc., Warranty Claim Dept., 710 Orange St., Ashland, OH 44805

If your product is new and not used and you wish to return it, contact your WaterSoft distributor.